



Iowa Prison Industries

Division of the Department of Corrections

406 North High Street
Anamosa, Iowa 52205

IPI Sign - Sign Digital Divisions



Phone: 1-800-336-7922

Fax: 1-800-741-0390

E-mail: ipicustomerservice@iowa.gov

or order from the website at www.iapisonind.com

This catalog includes a sampling of IPI's sign manufacturing capabilities. While IPI has made every effort to ensure MUTCD standards are current, please refer to the official MUTCD 2023 edition at: <http://mutcd.fhwa.dot.gov/>. Please contact Customer Service for any additional MUTCD or custom signs that you may need.

Dear Valued Customer:

We are pleased to present you with our newest Sign Selector catalog, developed from decades of experience as your signage provider. It contains more than 2000 products, from high-quality signs to many items you find useful in your own signage operations. These pages serve you well when determining your signage needs.

Iowa Prison Industries receives no taxpayer appropriations, which means our future as *Iowa's largest sign supplier* depends on your satisfaction.

Iowa Prison Industries is the largest rehabilitative program within the Iowa Department Of Corrections. We use the business model to teach Incarcerated Individuals (II's) marketable job skills, employing the latest techniques, including lean manufacturing and modern equipment, with the ultimate goal of returning them to society as honest citizens. Incarcerated Individuals who complete our program have a lower recidivism rate than those who do not. With you as our partner, we will continue to meet this vital commitment.

Please continue to use our products and provide us with the valuable input necessary for us to meet your needs. We anticipate a bright future working with you as we strive to meet our goals of providing you with a quality product that will improve the safety of our customers.

About Iowa Prison Industries

Iowa Prison Industries (IPI) is the work arm of the Iowa Department of Corrections and consists of manufacturing and private sector work programs. Each business is 100% self-funding and, since 1996, has returned over **\$10** million in revenue to the General Fund for education, taxes, family support and room and board.

Private Sector Work Programs are available to Incarcerated Individuals that are scheduled for release in three years or less. This special program operates under the Bureau of Justice, PIE Program and allows private companies to employ Incarcerated Individuals in various work programs.

In total, IPI employs over **700** Incarcerated Individuals daily in one of our work programs, accounting for over 1 million hours of Incarcerated Individual work training in the course of a year. Apprenticeship programs and certificates of completion are also offered through the Federal Department of Labor for on the job training.

Iowa Prison Industries has an Advisory Board consisting of private citizens representing banking, education, agriculture, labor, voc-education and one member of the parole board. Board meetings are held quarterly. The public is welcome to attend any meeting to better understand how they might play a role in Incarcerated Individual rehabilitation.

Iowa Prison Industries may produce and sell products to any tax-supported institution or governmental subdivision in any level of government which includes the state, city, or school corporation.

Iowa Prison Industries may sell products to employees of those entities, nonprofit organizations including parochial schools, churches, or fraternal organizations, nonprofit health care facilities serving Medicaid or social security patients.

IPI introduction to PIMMS

This is PIMMS: **The Prison Industries Manufacturing and Management System.**

Based on the Toyota Production System, PIMMS is a system of continuous improvement, using the talent and engagement of all IPI staff and all IPI associates (by which we mean Incarcerated men and women).

The heart of PIMMS is continuous learning and engagement by everyone in IPI, from production operations to the director. Only by drawing on the talents and hard work of everyone can we successfully carry out our Mission as a self-sufficient program that positively impacts participants lives, reduces recidivism, and provides valued products and services to our communities.

To learn more about PIMMS at IPI. Please request for a tour of our facilities closest to you, to see first hand, how it has improved our manufacturing processes at IPI.

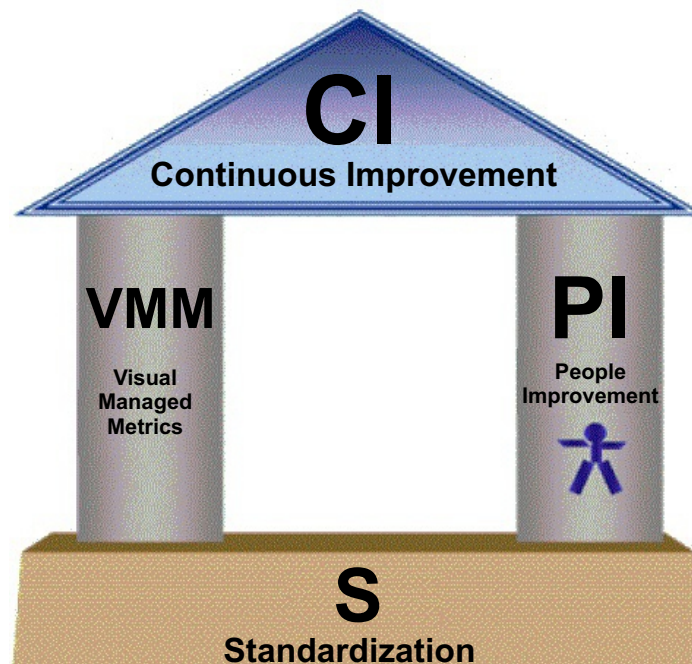

MUTCD 11th Edition Regulatory



R1-1



R1-3P



R1-2



R1-2aP



R1-2bP



R1-2cP

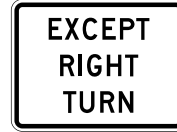

R1-10P



R1-5L



R1-5R



R1-5bL



R1-5bR



R1-5dL



R1-5dR



R1-5eL



R1-5eR



R1-6



R1-6a



R1-6d



R1-6e

* The legend STATE LAW is optional. A fluorescent yellow-green background color may be used instead of yellow for this sign.

Signs are not shown in proportion to their designated sizes.



R1-9



R1-9a



R1-9d



R1-9e

MUTCD 11th Edition Regulatory



R2-1

Specify Number



R2-2P

Specify Number



R2-2aP

Specify Number



R2-2bP

Specify Number



R2-4P

Specify Number



R2-4a

Specify Numbers



R2-5aP



R2-5bP



R2-5cP



R2-5P



R2-6P



R2-6aP



R2-6bP

Specify Number



R2-10



R2-11



R2-13

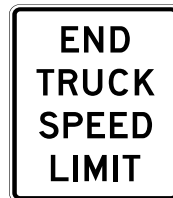

R2-14



R3-1



R3-1b



R3-1c



R3-1d

Specify Number



R3-1e



R3-1f



R3-1g

Specify Times and days of week



R3-1h

OR



MUTCD 11th Edition Regulatory



R3-2 R3-3 R3-4

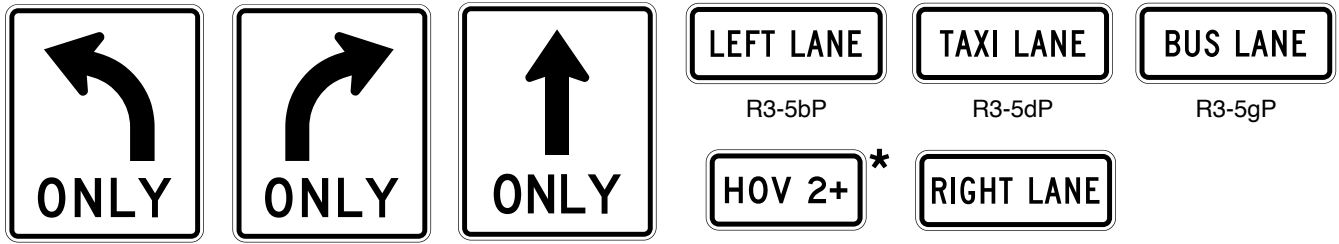

R3-5L R3-5R R3-5a R3-5bP R3-5dP R3-5gP R3-5cP R3-5fP

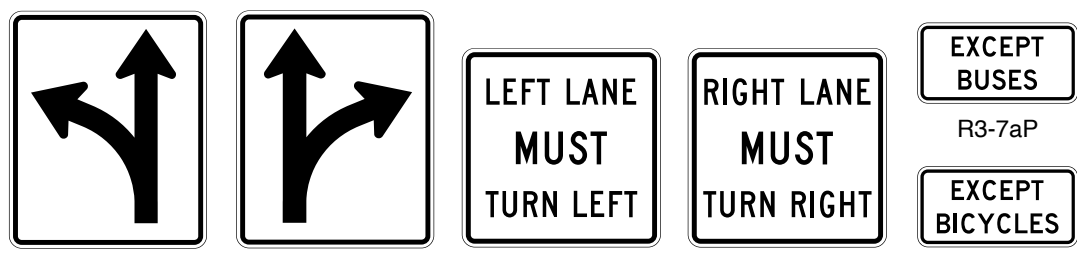

R3-6L R3-6R R3-7L R3-7R R3-7aP R3-7bP

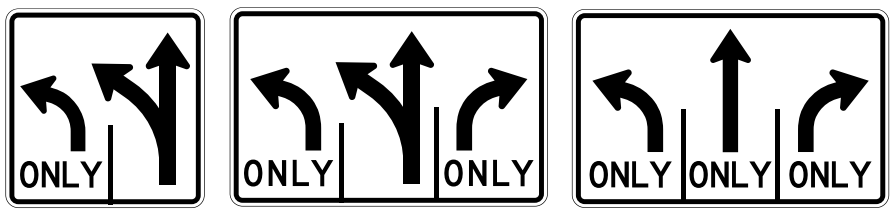

R3-8 R3-8a R3-8b

U] ^ & a; A i; [, A d a ^ & a; } • A A a e [~ • o A R ^ & q; { { ^ } a ^ a A

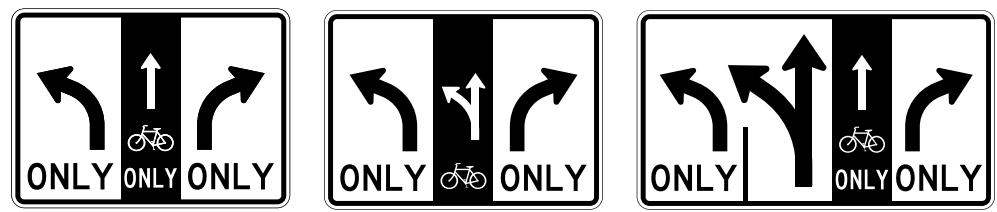

R3-8xa R3-8xb R3-8xc

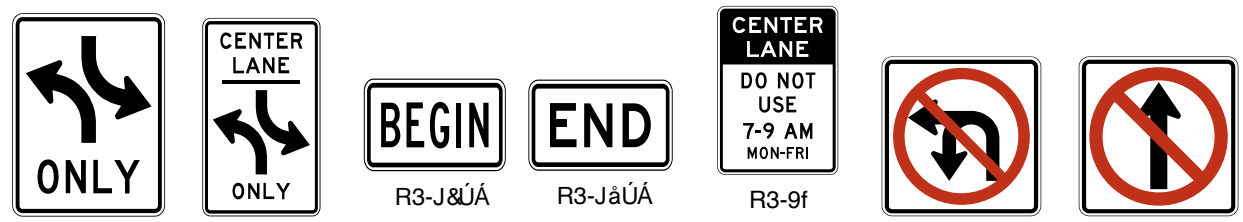

R3-JaA R3-JbA R3-J&UÁ R3-JaUÁ R3-9f R3-18A R3-27A

Specify Times / Days

MUTCD 11th Edition Regulatory



R4-1



R4-2

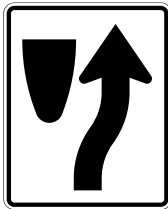

R4-7



R4-7a



R4-7b

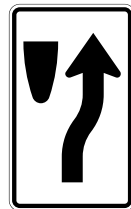

R4-7c

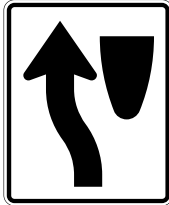

R4-8



R4-8a



R4-8b

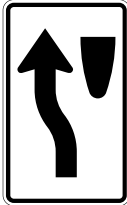

R4-8c



R5-1



R5-1a



R5-2



R5-2aP



R5-2b



R5-3



R5-4



R5-6



R5-11



R5-12



R6-1L



R6-1R



R6-2L



R6-2R



R6-3



R6-3a



R6-5P



R6-6



R6-7

MUTCD 11th Edition Regulatory



R7-1

Specify Arrow



R7-2

Specify Message - Arrow (See examples)



R7-2a

HERE TO
CORNER



R7-107

8:30 AM
TO 5:30 PM



R7-4

Specify Arrow



R7-4a

Specify Arrow



R7-6

Specify Arrow

BETWEEN
SIGNS

CORNER
TO HERE

THIS
SIDE

THIS SIDE
OF STREET

OR ANY
MESSAGE



R7-107a

Specify Arrow



R7-107b

Specify LOGO /
Arrow



OR



R7-201P



R7-201aP



R7-202P



R7-203



R8-1



R8-2



R8-3



R8-3a



R8-3c



R8-3d



R8-3e



R8-3f



R8-5



R8-6



R7-5

Specify Number /
Arrow



R7-20

Specify Number



R7-21



R7-22



R7-108

Specify Number / Message / Arrow

MUTCD 11th Edition Regulatory

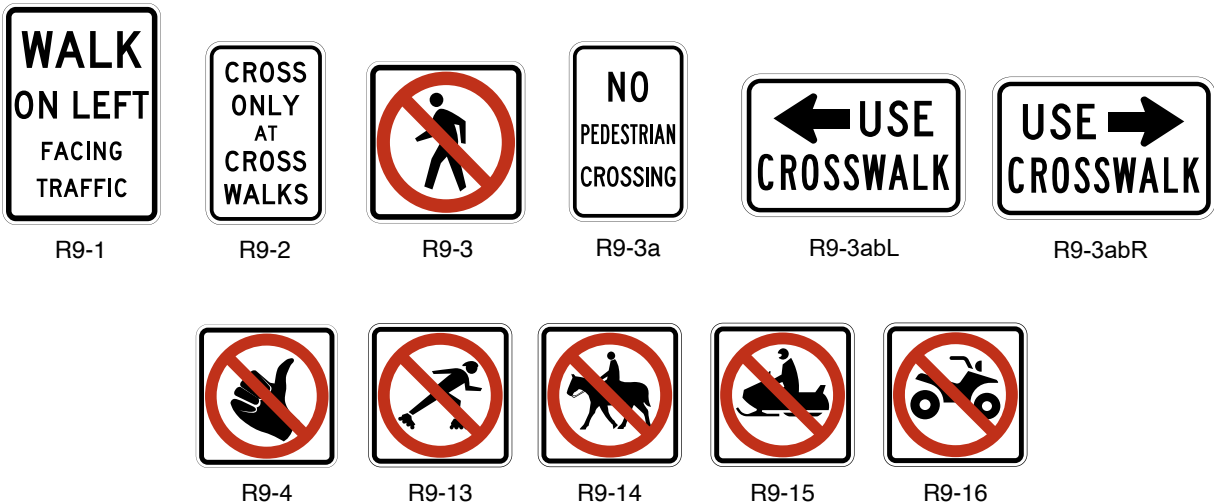
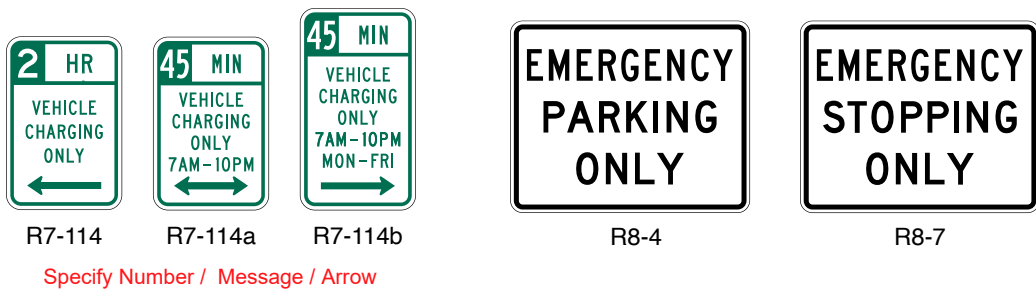
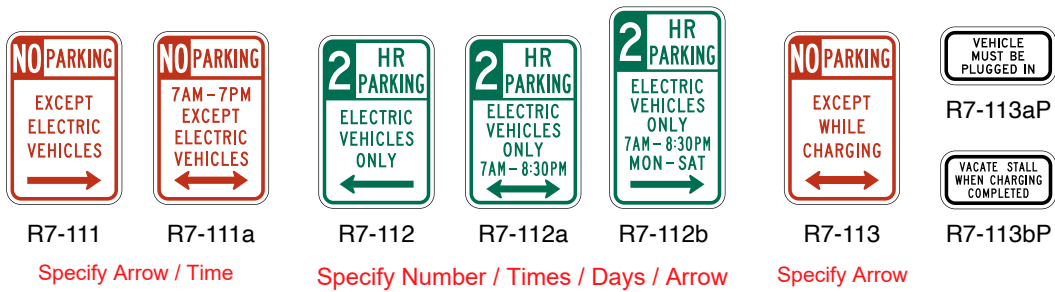
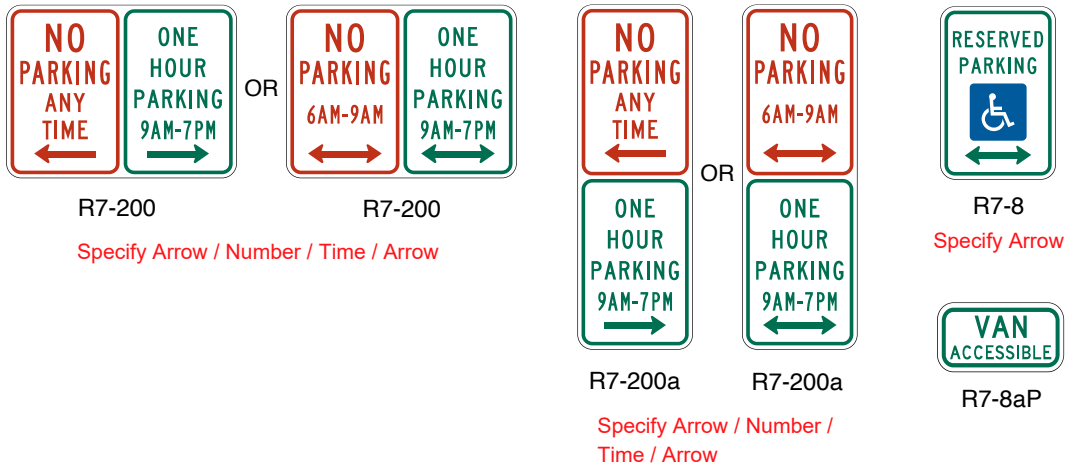

MUTCD 11th Edition Regulatory



R10-1



R10-2



R10-3

Specify Arrow



R10-3a

Specify Arrow

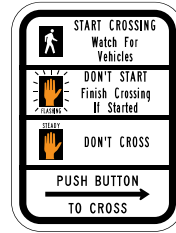

R10-3b

Specify Arrow

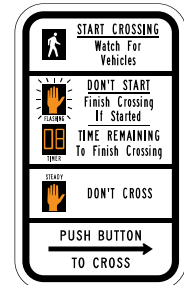

R10-3e

Specify Arrow



R10-4

Specify Arrow



R10-4a

Specify Arrow



R10-25



R10-5



R10-6L



R10-6R



R10-6aL



R10-6aR

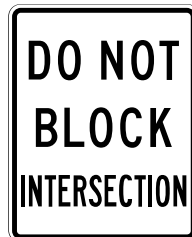

R10-7



R10-8

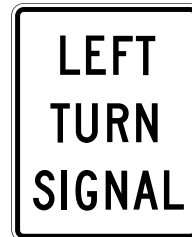

R10-10L

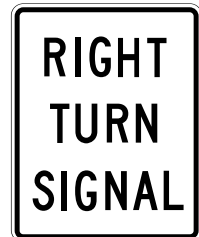

R10-10R

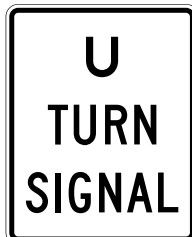

R10-10a

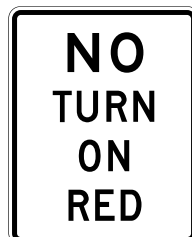

R10-11



R10-11a



R10-11b

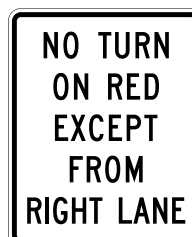

R10-11c

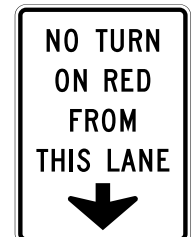

R10-11d

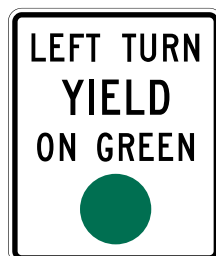

R10-12

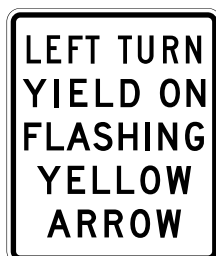

R10-12a

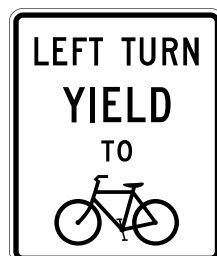

R10-12b



R10-13

MUTCD 11th Edition Regulatory

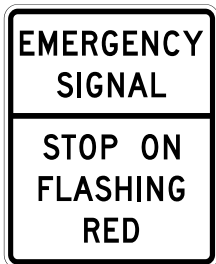

R10-14



R10-14a



R10-14bL



R10-14bR

★ A fluorescent yellow-green background color may be used instead of yellow for this sign.

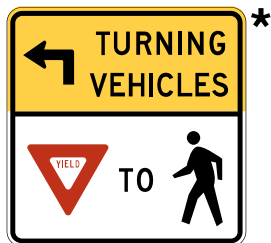

R10-15L

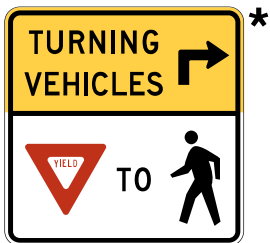

R10-15R



R10-15aL



R10-15aR

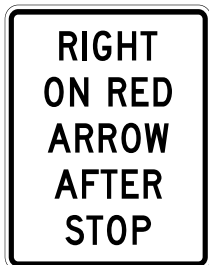

R10-17a



R10-18

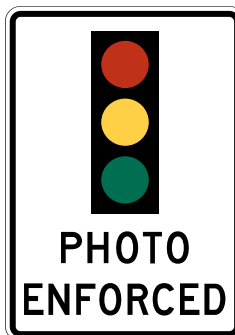

R10-18a



R10-19P



R10-19aP



R10-20aP

OR



Specify Days / Times



R10-23

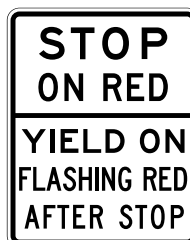

R10-23a



R10-27

MUTCD 11th Edition Regulatory



R11-1



R11-2



R11-2b



R11-2a



R11-2c



R11-3

Specify Number



R11-3a

Specify Number



R11-3b

Specify Number



R11-4 Specify which sign message



R12-1

Specify Number

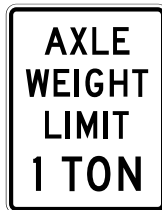

R12-2

Specify Number

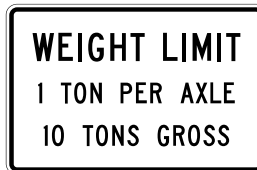

R12-4

Specify Numbers

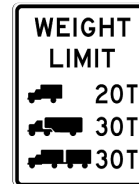

R12-5 IADOT

24X30

Specify Numbers

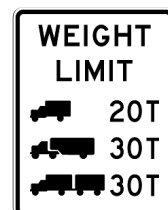

R12-5 IADOT

30X36

Specify Numbers

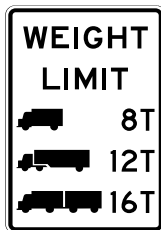

R12-5

Specify Numbers

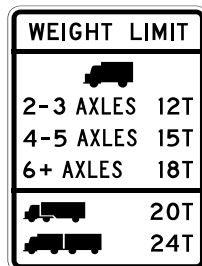

R12-6

Specify Numbers

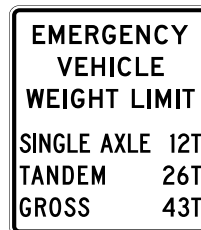

R12-7

Specify Numbers

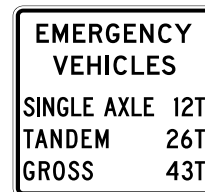

R12-7aP

Specify Numbers



R14-1



R14-2



R14-3

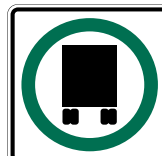

R14-4



R14-5

Table 2B-1. Regulatory Sign and Plaque Sizes (Sheet 1 of 6)

Sign or Plaque	Sign Designation	Section	Conventional Road		Expressway	Freeway	Minimum	Oversized
			Single Lane	Multi-Lane				
Stop	R1-1	2B.04	30 x 30	36 x 36	36 x 36	—	30 x 30*	48 x 48
Yield	R1-2	2B.05	36 x 36 x 36	48 x 48 x 48	48 x 48 x 48	60 x 60 x 60	30 x 30 x 30*	—
To Oncoming Traffic (plaque)	R1-2aP	2B.18	24 x 18	24 x 18	36 x 30	48 x 36	24 x 18	—
To Traffic in Circle (plaque)	R1-2bP	2B.18	24 x 15	24 x 15	—	—	24 x 15	36 x 24
To All Lanes (plaque)	R1-2cP	2B.18	24 x 15	24 x 15	—	—	24 x 15	36 x 24
All Way (plaque)	R1-3P	2B.04	18 x 6	18 x 6	—	—	—	30 x 12
Yield Here to Pedestrians	R1-5	2B.19	—	36 x 36	—	—	—	36 x 36
Stop Here for Pedestrians	R1-5b	2B.19	—	36 x 36	—	—	—	36 x 36
Yield Here to (Stop Here for) Trail Crossing	R1-5d,5e	2B.19	—	36 x 42	—	—	—	—
In-Street Pedestrian Crossing - Yield (Stop)	R1-6,6a	2B.20	12 x 36	12 x 36	—	—	—	—
In-Street Trail Crossing - Yield (Stop)	R1-6d,6e	2B.20	12 x 36	12 x 36	—	—	—	—
Overhead Pedestrian Crossing - Yield (Stop)	R1-9,9a	2B.20	90 x 24	90 x 24	—	—	—	—
Overhead Trail Crossing	R1-9d,9e	2B.20	72 x 24	72 x 24	—	—	—	—
Except Right Turn (plaque)	R1-10P	2B.04	24 x 18	24 x 18	—	—	—	—
Speed Limit	R2-1	2B.21	24 x 30	30 x 36	36 x 48	48 x 60	18 x 24	30 x 36
Truck Speed Limit (plaque)	R2-2P	2B.22	24 x 24	24 x 24	36 x 36	48 x 48	—	36 x 36
Bus Speed Limit (plaque)	R2-2aP	2B.22	24 x 24	24 x 24	36 x 36	48 x 48	—	36 x 36
Truck-Bus Speed Limit (plaque)	R2-2bP	2B.22	24 x 30	24 x 30	36 x 42	48 x 54	—	36 x 42
Vehicles Over X Tons Speed Limit (plaque)	R2-2cP	2B.22	24 x 30	24 x 30	36 x 42	48 x 54	—	36 x 42
Night Speed Limit (plaque)	R2-3P	2B.23	24 x 24	24 x 24	36 x 36	48 x 48	—	36 x 36
Minimum Speed Limit (plaque)	R2-4P	2B.24	24 x 24	24 x 24	36 x 36	48 x 48	—	36 x 36
Combined Maximum and Minimum Speed Limits	R2-4a	2B.24	24 x 48	24 x 48	36 x 72	48 x 96	—	36 x 72
Unless Otherwise Posted (plaque)	R2-5P	2B.21	24 x 18	24 x 18	36 x 24	36 x 24	—	36 x 24
Citywide (plaque)	R2-5aP	2B.21	24 x 6	24 x 6	—	—	—	30 x 9
Neighborhood (plaque)	R2-5bP	2B.21	24 x 6	24 x 6	—	—	—	30 x 9
Residential (plaque)	R2-5cP	2B.21	24 x 6	24 x 6	—	—	—	30 x 9
Fines Higher (plaque)	R2-6P	2B.25	24 x 18	24 x 18	36 x 24	48 x 36	—	36 x 24
Fines Double (plaque)	R2-6aP	2B.25	24 x 18	24 x 18	36 x 24	48 x 36	—	36 x 24
\$XX Fine (plaque)	R2-6bP	2B.25	24 x 18	24 x 18	36 x 24	48 x 36	—	36 x 24
Begin Higher Fines Zone	R2-10	2B.25	24 x 30	24 x 30	36 x 48	48 x 60	—	36 x 48
End Higher Fines Zone	R2-11	2B.25	24 x 30	24 x 30	36 x 48	48 x 60	—	36 x 48
End Variable Speed Limit	R2-13	2B.21	24 x 30	24 x 30	36 x 48	48 x 60	—	36 x 48
End Truck Speed Limit	R2-14	2B.21	24 x 30	24 x 30	36 x 48	48 x 60	—	36 x 48
Movement Prohibition	R3-1,2,3,4,18,27	2B.26	24 x 24	36 x 36	36 x 36	—	—	48 x 48
Movement Prohibition - Trucks	R3-1b	2B.26	24 x 36	24 x 36	36 x 54	36 x 54	—	—
Movement Prohibition - Trucks Buses	R3-1c	2B.26	24 x 42	24 x 42	36 x 60	36 x 60	—	—
Movement Prohibition - Trucks Over X Tons	R3-1d	2B.26	24 x 48	24 x 48	36 x 66	36 x 66	—	—
Movement Prohibition - Except Buses	R3-1e	2B.26	24 x 36	24 x 36	36 x 54	36 x 54	—	—
Movement Prohibition - Except Buses Taxis	R3-1f	2B.26	24 x 42	24 x 42	36 x 66	36 x 66	—	—
Movement Prohibition - Time and Day	R3-1g	2B.26	24 x 36	24 x 36	36 x 54	36 x 54	—	—

Table 2B-1. Regulatory Sign and Plaque Sizes (Sheet 2 of 6)

Sign or Plaque	Sign Designation	Section	Conventional Road		Expressway	Freeway	Minimum	Oversized
			Single Lane	Multi-Lane				
Movement Prohibition - Multiple Times and Day	R3-1h	2B.26	24 x 42	24 x 42	36 x 66	36 x 66	—	—
Mandatory Movement Lane Control	R3-5,5a	2B.28	30 x 36	30 x 36	—	—	—	—
Left Lane (plaque)	R3-5bP	2B.28	30 x 12	30 x 12	—	—	—	—
HOV 2+ (plaque)	R3-5cP	2B.28	24 x 12	24 x 12	—	—	—	—
Taxi Lane (plaque)	R3-5dP	2B.28	30 x 12	30 x 12	—	—	—	—
Right Lane (plaque)	R3-5fP	2B.28	30 x 12	30 x 12	—	—	—	—
Bus Lane (plaque)	R3-5gP	2B.28	30 x 12	30 x 12	—	—	—	—
Optional Movement Lane Control Thru and Turn	R3-6	2B.29	30 x 36	30 x 36	—	—	—	—
Optional Movement U and Left Turn	R3-6a	2B.29	30 x 36	30 x 36	—	—	—	—
Optional Movement Left Turns	R3-6b	2B.29	30 x 36	30 x 36	—	—	—	—
Right (Left) Lane Must Turn Right (Left)	R3-7	2B.28	30 x 30	36 x 36	48 x 48	—	—	48 x 48
Except Buses (plaque)	R3-7aP	2B.28	24 x 12	24 x 12	—	—	—	—
Except Bicycles (plaque)	R3-7bP	2B.28	24 x 12	24 x 12	—	—	—	—
Advance Intersection Lane Control	R3-8,8a,8b,8xa,8xb,8xc	2B.30	Varies x 30	Varies x 30	—	—	—	Varies x 36
Two-Way Left Turn Only (overhead)	R3-9a	2B.32	30 x 36	30 x 36	—	—	—	—
Two-Way Left Turn Only (post-mounted)	R3-9b	2B.32	24 x 36	24 x 36	—	—	—	36 x 48
Begin (plaque)	R3-9cP	2B.33	24 x 12	24 x 12	—	—	—	36 x 18
End (plaque)	R3-9dP	2B.33	24 x 12	24 x 12	—	—	—	36 x 18
Reversible Lane Control (overhead)	R3-9e	2B.34	108 x 48	108 x 48	—	—	—	—
Reversible Lane Control (post-mounted)	R3-9f	2B.34	30 x 42	36 x 54	—	—	—	—
Advance Reversible Lane Control Transition	R3-9g,9h	2B.34	108 x 36	108 x 36	—	—	—	—
End Reverse Lane	R3-9i	2B.34	108 x 48	108 x 48	—	—	—	—
Lane For Left Turn Only	R3-19	2B.28	30 x 24	30 x 24	—	—	—	—
Lane for U Turn Only	R3-19a	2B.28	30 x 24	30 x 24	—	—	—	—
Lane For U and Left Turns Only	R3-19b	2B.28	30 x 30	30 x 30	—	—	—	—
Begin Right (Left) Turn Lane	R3-20	2B.28	24 x 36	24 x 36	—	—	—	—
All Turns (U-Turn) from Right Lane	R3-23,23a	2B.35	60 x 36	60 x 36	—	—	—	—
All Turns (U-Turn) Directional	R3-24,24b,25,25b,26a	2B.35	72 x 18	72 x 18	—	—	—	—
U-Turns and Left Turns Directional	R3-24a,25a,26	2B.35	60 x 24	60 x 24	—	—	—	—
Right (Left) Lane Must Exit	R3-33	2B.31	—	—	78 x 36	78 x 36	—	—
Right (Left) Lane Must Exit	R3-33a	2B.31	—	—	42 x 60	42 x 60	—	—
Do Not Pass	R4-1	2B.36	24 x 30	24 x 30	36 x 48	48 x 60	18 x 24	36 x 48
Pass With Care	R4-2	2B.37	24 x 30	24 x 30	36 x 48	48 x 60	18 x 24	36 x 48
Slower Traffic Keep Right	R4-3	2B.38	24 x 30	24 x 30	36 x 48	48 x 60	18 x 24	36 x 48
Trucks Use Right Lane	R4-5	2B.38	24 x 30	24 x 30	36 x 48	48 x 60	—	36 x 48
Keep Right	R4-7,7a,7b	2B.39	24 x 30	24 x 30	36 x 48	48 x 60	18 x 24	36 x 48
Narrow Keep Right	R4-7c	2B.39	18 x 30	18 x 30	—	—	—	—
Keep Left	R4-8,8a,8b	2B.39	24 x 30	24 x 30	36 x 48	48 x 60	18 x 24	36 x 48
Narrow Keep Left	R4-8c	2B.39	18 x 30	18 x 30	—	—	—	—
Stay in Lane	R4-9	2B.40	24 x 30	24 x 30	36 x 48	48 x 60	18 x 24	36 x 48
Runaway Vehicles Only	R4-10	2B.41	48 x 48	48 x 48	—	—	—	—

Table 2B-1. Regulatory Sign and Plaque Sizes (Sheet 3 of 6)

Sign or Plaque	Sign Designation	Section	Conventional Road		Expressway	Freeway	Minimum	Oversized
			Single Lane	Multi-Lane				
Slow Vehicles with XX or More Following Vehicles Must Use Turn-Out	R4-12	2B.42	42 x 24	42 x 24	—	—	—	72 x 42
Slow Vehicles Must Use Turn-Out Ahead	R4-13	2B.42	42 x 24	42 x 24	—	—	—	—
Slow Vehicles Must Turn Out	R4-14	2B.42	30 x 42	30 x 42	—	—	—	—
Keep Right Except to Pass	R4-16	2B.38	24 x 30	24 x 30	36 x 48	48 x 60	18 x 24	36 x 48
Do Not Drive on Shoulder	R4-17	2B.43	24 x 30	24 x 30	36 x 48	48 x 60	18 x 24	36 x 48
Do Not Pass on Shoulder	R4-18	2B.43	24 x 30	24 x 30	36 x 48	48 x 60	18 x 24	36 x 48
All Traffic	R4-20	2B.44	24 x 30	24 x 30	36 x 48	48 x 60	—	36 x 48
Right (Left) Turn Only	R4-21	2B.44	24 x 30	24 x 30	—	—	—	—
Do Not Enter	R5-1	2B.46	30 x 30	36 x 36	36 x 36	48 x 48	—	36 x 36
Wrong Way	R5-1a	2B.47	36 x 24	42 x 30	36 x 24	42 x 30	30 x 18	42 x 30
No Trucks	R5-2	2B.45	24 x 24	24 x 24	30 x 30	36 x 36	—	36 x 36
Except Local Deliveries (plaque)	R5-2aP	2B.45	24 x 12	24 x 12	30 x 15	36 x 18	—	36 x 18
No Thru Trucks	R5-2b	2B.45	24 x 30	24 x 30	30 x 36	36 x 48	—	36 x 48
No Motor Vehicles	R5-3	2B.45	24 x 24	24 x 24	—	—	24 x 24	—
No Commercial Vehicles	R5-4	2B.45	24 x 30	24 x 30	36 x 48	36 x 48	—	—
No Vehicles with Lugs	R5-5	2B.45	24 x 30	24 x 30	36 x 48	48 x 60	—	—
No Bicycles	R5-6	2B.45	24 x 24	24 x 24	30 x 30	36 x 36	24 x 24*	48 x 48
No Non-Motorized Traffic	R5-7	2B.45	30 x 24	30 x 24	42 x 24	48 x 30	—	42 x 24
No Motor-Driven Cycles	R5-8	2B.45	30 x 24	30 x 24	42 x 24	48 x 30	—	42 x 24
No Pedestrians, Bicycles, Motor-Driven Cycles	R5-10	2B.45	30 x 36	30 x 36	—	—	—	—
No Pedestrians, Bicycles, Motor-Driven Cycles On Freeway	R5-10a	2B.45	30 x 36	30 x 36	—	—	—	—
No Pedestrians or Bicycles	R5-10b	2B.45	30 x 18	30 x 18	—	—	—	—
No Pedestrians	R5-10c	2B.45	24 x 12	24 x 12	—	—	—	—
Authorized Vehicles Only	R5-11	2B.45	30 x 24	30 x 24	—	—	—	—
No Thru Traffic	R5-12	2B.45	24 x 30	24 x 30	—	—	—	30 x 36
One Way	R6-1	2B.49	36 x 12	48 x 18	48 x 18	48 x 18	—	72 x 24
One Way	R6-2	2B.49	24 x 30	30 x 36	36 x 48	48 x 60	18 x 24	36 x 48
Divided Highway Crossing	R6-3,3a	2B.50	30 x 24	30 x 24	36 x 30	—	—	36 x 30
Roundabout Circulation (plaque)	R6-5P	2B.51	30 x 30	30 x 30	—	—	—	—
Begin One Way	R6-6	2B.49	24 x 30	30 x 36	—	—	—	—
End One Way	R6-7	2B.49	24 x 30	30 x 36	—	—	—	—
Parking Restrictions	R7-1,2,2a,3,4,4a,5,6,8,10,107,108	2B.52, 2B.53	12 x 18	12 x 18	—	—	—	18 x 24 IA DOT
Van Accessible (plaque)	R7-8aP	2B.52, 2B.53	12 x 6	12 x 6	—	—	—	—
Parking Fee Station, Multispace Meter	R7-20	2B.52, 2B.53	24 x 18	24 x 18	—	—	—	—
Metered Parking	R7-21	2B.52, 2B.53	12 x 18	12 x 18	—	—	—	—
Mobile Parking Payment (plaque)	R7-21aP	2B.52, 2B.53	12 x 6	12 x 6	—	—	—	—
Metered Parking	R7-22	2B.52, 2B.53	12 x 18	12 x 18	—	—	—	—
No Parking Bus Stop	R7-107a	2B.52, 2B.53	12 x 24	12 x 24	—	—	—	—
No Parking Bus Stop (with transit pictograph)	R7-107b	2B.52, 2B.53	12 x 30	12 x 30	—	—	—	—

Table 2B-1. Regulatory Sign and Plaque Sizes (Sheet 4 of 6)

Sign or Plaque	Sign Designation	Section	Conventional Road		Expressway	Freeway	Minimum	Oversized
			Single Lane	Multi-Lane				
No Parking Except Electric Vehicles	R7-111	2B.52, 2B.53	12 x 18	12 x 18	—	—	—	—
No Parking Except Electric Vehicles (part-time)	R7-111a	2B.52, 2B.53	12 x 18	12 x 18	—	—	—	—
Electric Vehicle Parking (time limit)	R7-112	2B.52, 2B.53	12 x 18	12 x 18	—	—	—	—
Electric Vehicle Parking (time limit part-time)	R7-112a	2B.52, 2B.53	12 x 18	12 x 18	—	—	—	—
Electric Vehicle Parking (time limit part-time)	R7-112b	2B.52, 2B.53	12 x 21	12 x 21	—	—	—	—
No Parking Except While Charging	R7-113	2B.52, 2B.53	12 x 18	12 x 18	—	—	—	—
Vehicle Must Be Plugged In (plaque)	R7-113aP	2B.52, 2B.53	12 x 6	12 x 6	—	—	—	—
Vacate Stall When Charging Completed (plaque)	R7-113bP	2B.52, 2B.53	12 x 6	12 x 6	—	—	—	—
Vehicle Charging Only (time limit)	R7-114	2B.52, 2B.53	12 x 18	12 x 18	—	—	—	—
Vehicle Charging Only (time limit, part-time)	R7-114a	2B.52, 2B.53	12 x 18	12 x 18	—	—	—	—
Vehicle Charging Only (time limit part-time)	R7-114b	2B.52, 2B.53	12 x 21	12 x 21	—	—	—	—
No Parking/Restricted Parking (combined sign)	R7-200	2B.52, 2B.53	24 x 18	24 x 18	—	—	—	—
No Parking/Restricted Parking (combined sign)	R7-200a	2B.52, 2B.53	12 x 36	12 x 36	—	—	—	—
Tow Away Zone (plaque)	R7-201P, 201aP	2B.52, 2B.53	12 x 6	12 x 6	—	—	—	—
This Side of Sign (plaque)	R7-202P	2B.52, 2B.53	12 x 6	12 x 6	—	—	—	—
Snow Emergency Route	R7-203	2B.52, 2B.53	18 x 24	18 x 24	—	—	—	24 x 30
No Parking on Pavement	R8-1	2B.52, 2B.53	24 x 30	24 x 30	36 x 48	48 x 60	—	36 x 48
No Parking Except on Shoulder	R8-2	2B.52, 2B.53	24 x 30	24 x 30	36 x 48	48 x 60	—	36 x 48
No Parking (symbol)	R8-3	2B.52, 2B.53	24 x 24	30 x 30	36 x 36	48 x 48	12 x 12	36 x 36
No Parking	R8-3a	2B.52, 2B.53	24 x 30	24 x 30	36 x 36	48 x 48	18 x 24	36 x 36
On Pavement	R8-3c	2B.52, 2B.53	24 x 36	24 x 36	—	—	18 x 30	36 x 54
On Bridge	R8-3d	2B.52, 2B.53	24 x 36	24 x 36	—	—	18 x 30	36 x 54
On Tracks	R8-3e	2B.52, 2B.53	24 x 36	24 x 36	—	—	18 x 30	36 x 54
Except on Shoulder	R8-3f	2B.52, 2B.53	24 x 36	24 x 36	—	—	18 x 30	36 x 54
Emergency Parking Only	R8-4	2B.55	30 x 24	30 x 24	30 x 24	48 x 36	—	48 x 36
No Stopping on Pavement	R8-5	2B.53, 2B.54	24 x 30	24 x 30	36 x 48	48 x 60	—	36 x 48
No Stopping Except on Shoulder	R8-6	2B.53, 2B.54	24 x 30	24 x 30	36 x 48	48 x 60	—	36 x 48
Emergency Stopping Only	R8-7	2B.55	30 x 24	30 x 24	48 x 36	48 x 36	—	48 x 36
Walk on Left Facing Traffic	R9-1	2B.56	18 x 24	18 x 24	—	—	—	—
Cross Only at Crosswalks	R9-2	2B.57	12 x 18	12 x 18	—	—	—	—
No Pedestrian Crossing (symbol)	R9-3	2B.57	18 x 18	18 x 18	24 x 24	30 x 30	—	30 x 30
No Pedestrian Crossing	R9-3a	2B.57	12 x 18	12 x 18	—	—	—	—

Table 2B-1. Regulatory Sign and Plaque Sizes (Sheet 5 of 6)

Sign or Plaque	Sign Designation	Section	Conventional Road		Expressway	Freeway	Minimum	Oversized
			Single Lane	Multi-Lane				
Use Crosswalk (plaque)	R9-3bP	2B.57	18 x 12	18 x 12	—	—	—	—
No Hitchhiking (symbol)	R9-4	2B.56	18 x 18	18 x 18	—	—	—	24 x 24
No Hitchhiking	R9-4a	2B.56	18 x 24	18 x 24	—	—	12 x 18	—
No Skaters	R9-13	2B.45	18 x 18	18 x 18	24 x 24	30 x 30	—	30 x 30
No Equestrians	R9-14	2B.45	18 x 18	18 x 18	24 x 24	30 x 30	—	30 x 30
No Snowmobiles	R9-15	2B.45	18 x 18	18 x 18	24 x 24	30 x 30	—	30 x 30
No All-Terrain Vehicles	R9-16	2B.45	18 x 18	18 x 18	24 x 24	30 x 30	—	30 x 30
Except on Shoulder (plaque)	R9-19P	2B.45	18 x 12	18 x 12	24 x 18	30 x 24	—	30 x 24
Cross Only On Green	R10-1	2B.58	12 x 18	12 x 18	—	—	—	—
Pedestrian Signs	R10-2,3,3b,3c,3d,4	2B.58	9 x 12	9 x 12	—	—	—	—
Pedestrian Signs	R10-3a,3e,3f,3g,3h,3i,4a	2B.58	9 x 15	9 x 15	—	—	—	—
Left on Green Arrow Only	R10-5	2B.59	30 x 36	30 x 36	30 x 36	—	24 x 30	48 x 60
Stop Here on Red	R10-6	2B.59	24 x 36	24 x 36	—	—	—	36 x 48
Stop Here on Red	R10-6a	2B.59	24 x 30	24 x 30	—	—	—	36 x 42
Do Not Block Intersection	R10-7	2B.59	24 x 30	24 x 30	—	—	—	—
Use Lane with Green Arrow	R10-8	2B.59	30 x 36	30 x 36	36 x 42	—	—	60 x 72
Left (Right) Turn Signal	R10-10	2B.59	24 x 30	24 x 30	—	—	—	30 x 36
U- Turn Signal	R10-10a	2B.59	24 x 30	24 x 30	—	—	—	30 x 36
No Turn on Red	R10-11	2B.60	24 x 30	24 x 30	—	—	—	36 x 48
No Turn on Circular Red	R10-11a	2B.60	24 x 30	24 x 30	—	—	—	36 x 48
No Turn on Red	R10-11b	2B.60	24 x 24	24 x 24	—	—	—	36 x 36
No Turn on Red Except From Right Lane	R10-11c	2B.60	30 x 36	30 x 36	—	—	—	—
No Turn on Red From This Lane	R10-11d	2B.60	30 x 42	30 x 42	—	—	—	—
Left Turn Yield on Green	R10-12	2B.59	30 x 36	30 x 36	—	—	—	—
Left Turn Yield on Flashing Yellow Arrow	R10-12a	2B.59	30 x 36	30 x 36	—	—	—	—
Left Turn Yield to Bicycle	R10-12b	2B.59	30 x 36	30 x 36	—	—	—	—
Emergency Signal	R10-13	2B.59	36 x 24	36 x 24	—	—	—	42 x 30
Emergency Signal - Stop on Flashing Red	R10-14	2B.59	36 x 42	36 x 42	—	—	—	—
Emergency Signal - Stop on Flashing Red (overhead)	R10-14a	2B.59	60 x 24	60 x 24	—	—	—	—
Stop Here on Flashing Red	R10-14b	2B.59	24 x 36	24 x 36	—	—	—	36 x 48
Turning Vehicles Yield to Pedestrians	R10-15	2B.59	30 x 30	30 x 30	—	—	—	—
Turning Vehicles Stop for Pedestrians	R10-15a	2B.59	30 x 30	30 x 30	—	—	—	—
U-Turn Yield to Right Turn	R10-16	2B.59	30 x 36	30 x 36	—	—	—	—
Right on Red Arrow After Stop	R10-17a	2B.60	30 x 36	30 x 36	—	—	—	36 x 48
Traffic Laws Photo Enforced	R10-18	2B.69	36 x 24	36 x 24	48 x 30	54 x 36	—	54 x 36
Traffic Signal Photo Enforced	R10-18a	2B.69	30 x 42	30 x 42	30 x 42	—	—	36 x 54
Photo Enforced (symbol plaque)	R10-19P	2B.69	24 x 12	24 x 12	36 x 18	48 x 24	—	48 x 24
Photo Enforced (plaque)	R10-19aP	2B.69	24 x 18	24 x 18	36 x 24	48 x 36	—	48 x 36
MON—FRI (and times) (3 lines) (plaque)	R10-20aP	2B.60	24 x 24	24 x 24	—	—	—	—
SUNDAY (and times) (2 lines) (plaque)	R10-20aP	2B.60	24 x 18	24 x 18	—	—	—	—
Crosswalk - Stop on Red	R10-23	2B.59	24 x 30	24 x 30	—	—	—	—

Table 2B-1. Regulatory Sign and Plaque Sizes (Sheet 6 of 6)

Sign or Plaque	Sign Designation	Section	Conventional Road		Expressway	Freeway	Minimum	Oversized
			Single Lane	Multi-Lane				
Stop on Red - Yield on Flashing Red After Stop	R10-23a	2B.59	24 x 30	24 x 30	—	—	—	—
Push Button For Warning Lights - Wait for Gap in Traffic	R10-25	2B.58	9 x 12	9 x 12	—	—	—	—
Left Turn Yield on Flashing Red Arrow After Stop	R10-27	2B.59	30 x 36	30 x 36	—	—	—	—
XX Vehicles per Green	R10-28	2B.61	24 x 30	24 x 30	—	—	—	—
XX Vehicles per Green Each Lane	R10-29	2B.61	36 x 24	36 x 24	—	—	—	—
Right Turn on Red Must Yield to U-Turn	R10-30	2B.60	30 x 36	30 x 36	—	—	—	—
At Signal (plaque)	R10-31P	2B.59	24 x 9	24 x 9	—	—	—	—
Push Button for 2 Seconds for Extra Crossing Time	R10-32P	2B.58	9 x 12	9 x 12	—	—	—	—
Keep Off Median	R11-1	2B.62	24 x 30	24 x 30	—	—	—	—
Road Closed	R11-2,2a,2b,2c	2B.63	48 x 30	48 x 30	—	—	—	—
Road Closed - Local Traffic Only	R11-3,3a,3b,4	2B.63	60 x 30	60 x 30	—	—	—	—
Weight Limit	R12-1, 2	2B.64	24 x 30	24 x 30	36 x 48	—	—	36 x 48
Weight Limit - Axle, Gross	R12-4	2B.64	36 x 24	36 x 24	—	—	—	—
Weight Limit	R12-5	2B.64	24 x 36	24 x 36	36 x 48	48 x 60	—	—
Weight Limit - Specialized Hauling Vehicles	R12-6	2B.64	30 x 42	36 x 48	36 x 48	48 x 60	—	48 x 60
Weight Limit - Emergency Vehicles	R12-7	2B.64	30 x 36	30 x 36	48 x 60	48 x 60	—	48 x 60
Weight Limit - Emergency Vehicles (plaque)	R12-7aP	2B.64	30 x 30	30 x 30	48 x 48	48 x 48	—	48 x 48
Weigh Station	R13-1	2B.65	72 x 54	72 x 54	96 x 72	132 x 90	—	—
Truck Route	R14-1	2B.66	24 x 18	24 x 18	—	—	—	—
Hazardous Material	R14-2,3	2B.67	24 x 24	24 x 24	30 x 30	36 x 36	—	42 x 42
National Network	R14-4,5	2B.68	30 x 30	30 x 30	36 x 36	36 x 36	—	42 x 42
Move Over or Reduce Speed	R16-3	2B.71	—	60 x 48	84 x 60	102 x 72	—	84 x 60
Minor Crashes Move Vehicles from Travel Lanes	R16-4	2B.70	—	60 x 42	84 x 54	96 x 60	—	84 x 54
Lights On When Using Wipers or Raining	R16-5,6	2B.73	24 x 30	24 x 30	36 x 48	48 x 60	—	36 x 48
Turn On Headlights Next XX Miles	R16-7	2B.73	60 x 18	60 x 18	96 x 30	132 x 36	—	96 x 30
Turn On, Check Headlights	R16-8,9	2B.73	42 x 18	42 x 18	60 x 30	78 x 36	—	60 x 30
Begin, End Daytime Headlight Section	R16-10,11	2B.73	60 x 18	60 x 18	96 x 30	120 x 36	—	96 x 30
No Hand-Held Phone Use By Driver	R16-15	2B.72	—	—	72 x 48	72 x 48	—	—
No Hand-Held Phone Use By Driver	R16-15a	2B.72	30 x 42	30 x 42	—	—	—	—

* See Table 9A-1 for minimum size required for signs on bicycle facilities

Notes: 1. Larger signs may be used when appropriate 2. Dimensions in inches are shown as width x height

MUTCD 11th Edition Conventional Road Guide



M1-1
Specify Number



M2-1



M3-1



M3-2



M3-3



M3-4



M4-7



M4-7a



M4-5



M5-1PL



M5-1PR



M5-2PL



M5-2PR



M6-1P



M6-2PL



M6-2PR



M6-3P



M6-4P



M6-5PL



M6-5PR



M6-6PL



M6-6PR



M6-7PL



M6-7PR



Off-Interstate Business Route Sign
M1-2 (Loop)

Specify Number



Off-Interstate Business Route Sign
M1-3 (Spur)

MUTCD 11th Edition Conventional Road Guide



U.S. Route Signs

M1-4

Specify Number



State Route Signs

M1-5

Specify Number



M2-1P



M2-2

Specify Numbers /
Route Symbols



M3-1P



M3-2P



M3-3P



M3-4P



M4-1P



M4-1aP



M4-2P



M4-3P



M4-4P



M4-5P



M4-6P



M4-7P



M4-7aP



M4-14P



M5-1PL



M5-1PR

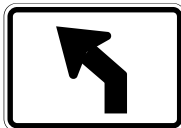

M5-2PL

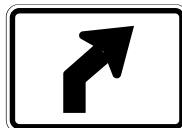

M5-2PR

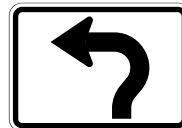

M5-3PL

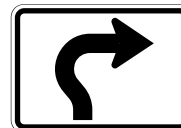

M5-3PR

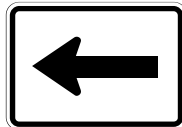

M6-1P



M6-2PL



M6-2PR



M6-2aPL



M6-2aPR



M6-3P

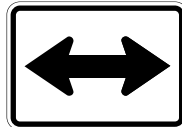

M6-4P

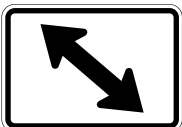

M6-5PL

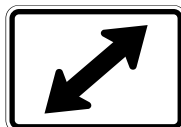

M6-5PR



M6-6PL



M6-6PR

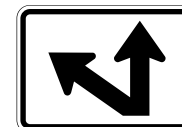

M6-7PL

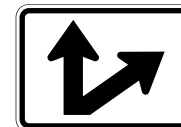

M6-7PR

MUTCD 11th Edition Conventional Road Guide



M1-6



M2-1P

Specify Number



M3-1P



M3-2P



M3-3P



M3-4P



M4-1P



M4-1aP



M4-2P



M4-3P



M4-4P



M4-5P



M4-6P



M4-7P



M4-7aP



M4-14P



M5-1PL



M5-1PR



M5-2PL



M5-2PR



M5-3PL



M5-3PR



M6-1P



M6-2PL



M6-2PR



M6-2aPL



M6-2aPR



M6-3P

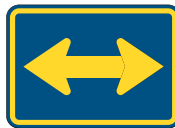

M6-4P



M6-5PL



M6-5PR



M6-6PL



M6-6PR



M6-7PL



M6-7PR

MUTCD 11th Edition Conventional Road Guide



D1-1



D1-2



D1-3

Specify Arrow Direction and Destination



D1-1a



D1-2a

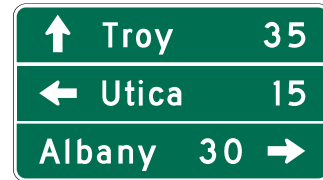

D1-3a

Specify Arrow Destination, Destination and Miles



D2-1



D2-2



D2-3

Specify Destination - Miles



D3-1

Specify Destination - Arrow



D3-1a

Specify Destination - Arrow -
Route symbol - Number



D4-1

Specify Arrow

Table 2D-1. Conventional Road Guide Sign and Plaque Sizes (Sheet 1 of 2)

Sign or Plaque	Designation	Section	Conventional Road	Minimum	Oversized
Interstate Route (1 or 2 digits)	M1-1,1a	2D.11	24 x 24	—	36 x 36
Interstate Route (3 digits)	M1-1,1a	2D.11	30 x 24	—	45 x 36
Off-Interstate Route (1 or 2 digits)	M1-2,3	2D.11	24 x 24	—	36 x 36
Off-Interstate Route (3 digits)	M1-2,3	2D.11	30 x 24	—	45 x 36
U.S. Route (1 or 2 digits)	M1-4	2D.11	24 x 24	—	36 x 36
U.S. Route (3 digits)	M1-4	2D.11	30 x 24	—	45 x 36
State Route (1 or 2 digits)	M1-5	2D.11	24 x 24	—	36 x 36
State Route (3 digits)	M1-5	2D.11	30 x 24	—	45 x 36
County Route	M1-6	2D.11	24 x 24	—	36 x 36
Forest Route	M1-7	2D.11	24 x 24	18 x 18	36 x 36
Junction (plaque)	M2-1P	2D.13	21 x 15	—	30 x 21
Combination Junction (2 route signs)	M2-2	2D.14	60 x 48*	—	—
Cardinal Direction (plaque)	M3-1P,2P,3P,4P	2D.15	24 x 12	—	36 x 18
Alternate (plaque)	M4-1P,1aP	2D.17	24 x 12	—	36 x 18
By-Pass (plaque)	M4-2P	2D.18	24 x 12	—	36 x 18
Business (plaque)	M4-3P	2D.19	24 x 12	—	36 x 18
Truck (plaque)	M4-4P	2D.20	24 x 12	—	36 x 18
To (plaque)	M4-5P	2D.21	24 x 12	—	36 x 18
End (plaque)	M4-6P	2D.22	24 x 12	—	36 x 18
Temporary (plaque)	M4-7P,7aP	2D.24	24 x 12	—	36 x 18
Emergency Route	M4-11	2D.59	30 x 30	—	—
Emergency Route	M4-11a	2D.59	30 x 30	—	—
Emergency Route To (plaque)	M4-11bP, 11cP	2D.59	30 x 18	—	—
End Emergency Route	M4-12	2D.59	24 x 18	—	—
Begin (plaque)	M4-14P	2D.23	24 x 12	—	36 x 18
Advance Turn Arrow (plaque)	M5-1P,2P,3P	2D.26	21 x 15	—	30 x 21
Lane Designation (plaque)	M5-4P,5P,6P	2D.27	24 x 18	—	36 x 24
Directional Arrow (plaque)	M6-1P,2P,2aP, 3P,4P,5P,6P,7P	2D.28	21 x 15	—	30 x 21
National Scenic Byway	M10-1	2D.57	24 x 24	—	—
National Scenic Byway (plaque)	M10-1aP	2D.57	24 x 12	—	—
Byway Identification	M10-2	2D.58	24 x 24	—	—
Byway Identification (plaque)	M10-2aP	2D.58	24 x 12	—	—
State Scenic Byway System	M10-3	2D.58	24 x 24	—	—
State Scenic Byway - Simple Graphic and Byway Identification	M10-3a	2D.58	24 x 24	—	—
Scenic Byway (plaque)	M10-3bP	2D.58	24 x 12	—	—
National Historic Trail - Identification	M11-1	2D.58	24 x 24	—	—
National Historic Trail - Historic Route (plaque)	M11-1aP	2D.58	24 x 12	—	—
National Historic Trail - Crossing (plaque)	M11-1bP	2D.58	24 x 12	—	—
National Historic Trail - Auto Tour Route (plaque)	M11-1cP	2D.58	24 x 12	—	—
National Historic Trail - Distance (plaque)	M11-1dP	2D.58	24 x 12	—	—
Destination (1 line)	D1-1	2D.36	Varies x 18	—	—
Destination and Distance (1 line)	D1-1a	2D.36	Varies x 18	—	—
Circular Intersection Destination (1 line)	D1-1d	2D.39	Varies x 18	—	—
Circular Intersection Departure Guide	D1-1e	2D.39	Varies x 42*	—	—
Destination (2 lines)	D1-2	2D.36	Varies x 30	—	—
Destination and Distance (2 lines)	D1-2a	2D.36	Varies x 30	—	—
Circular Intersection Destination (2 lines)	D1-2d	2D.39	Varies x 30	—	—

Table 2D-1. Conventional Road Guide Sign and Plaque Sizes (Sheet 2 of 2)

Sign or Plaque	Designation	Section	Conventional Road	Minimum	Oversized
Destination (3 lines)	D1-3	2D.36	Varies x 42	—	—
Destination and Distance (3 lines)	D1-3a	2D.36	Varies x 42	—	—
Circular Intersection Destination (3 lines)	D1-3d	2D.39	Varies x 42	—	—
Circular Intersection Diagrammatic Destination	D1-5	2D.39	Varies x 72*	—	—
Circular Intersection Diagrammatic Destination, Right-Turn Bypass	D1-5a	2D.39	Varies x 78*	—	—
Distance (1 line)	D2-1	2D.43	Varies x 18	—	—
Distance (2 lines)	D2-2	2D.43	Varies x 30	—	—
Distance (3 lines)	D2-3	2D.43	Varies x 42	—	—
Street Name (1 line)	D3-1,1a	2D.45	Varies x 12	Varies x 8	Varies x 18
Overhead Street Name (1 line)	D3-1,1a	2D.45	Varies x 24	—	—
Street Name (2 lines)	D3-1,1a	2D.45	Varies x 24	Varies x 15	Varies x 33
Overhead Street Name (2 lines)	D3-1,1a	2D.45	Varies x 48	—	—
Advance Street Name (2 lines)	D3-2	2D.46	Varies x 30	—	—
Advance Street Name (3 lines)	D3-2	2D.46	Varies x 42	—	—
Advance Street Name (4 lines)	D3-2	2D.46	Varies x 54	—	—
Parking Area Directional	D4-1	2D.47	30 x 24	18 x 15	—
Park - Ride	D4-2	2D.48	30 x 36	24 x 30	36 x 48
Advance Weigh Station Distance	D8-1	2D.51	78 x 60	60 x 48	96 x 72
Weigh Station Ahead	D8-1a	2D.51	66 x 48	48 x 36	—
Weigh Station Advance Direction	D8-2	2D.51	84 x 72	66 x 54	108 x 90
Weigh Station Entrance Direction	D8-3	2D.51	66 x 60	48 x 42	84 x 78
Crossover	D13-1,2	2D.52	60 x 30	—	78 x 42
Freeway Entrance	D13-3	2D.50	48 x 30	—	—
Freeway Entrance (Directional)	D13-3a	2D.50	48 x 42	—	—
Combination Lane Use / Destination	D15-1	2D.38	Varies x 96	—	—
Next Truck Lane	D17-1	2D.53	42 x 48	—	60 x 66
Advance Truck Lane	D17-2	2D.53	42 x 42	—	60 x 54
Next Passing Lane	D17-3	2D.53	42 x 48	—	60 x 66
Advance Passing Lane	D17-4	2D.53	42 x 42	—	60 x 54
Advance Emergency Turn-Out	D17-5	2D.54	60 x 36	—	78 x 54
Emergency Turn-Out (Directional)	D17-6	2D.54	60 x 36	—	78 x 60
Advance Slow Vehicle Turn-Out	D17-7	2D.54	72 x 36	—	96 x 54

*The size shown is for a typical sign. The size should be determined based on the amount of legend required for the sign.

Notes: 1. Larger signs may be used when appropriate

2. Dimensions in inches are shown as width x height

MUTCD 11th Edition General Information



D9-19



D9-19aP



D9-19bP



M4-6P



M4-14P



W16-19P



D10-1



D10-2



D10-3



D10-1a



D10-2a



D10-3a

Specify Mile Marker Number

Specify Mile Marker Number



D10-4



D10-5

Specify Direction, Symbol w/ Number & Mile Marker Number

MUTCD 11th Edition General Information



I1-1



I2-1



I2-2

Specify River Name



I3-5
Airport



I3-6
Bus Station



I3-7
Train Station



I3-8
Light Rail
Transit Station



I3-9
Vehicle Ferry
Terminal



I3-10
Passengers Only
Ferry Terminal



I4-1
Library



I4-2



I3-10P



M5-1PL



M5-1PR



M5-2PL



M5-2PR



M5-3PL



M5-3PR



M6-1P



M6-2PL



M6-2PR



M6-3P



Example of
directional
assembly

Table 2H-1. General Information Sign and Plaque Sizes

Sign	Sign Designation	Section	Conventional Road	Freeway or Expressway
Alternative Fuels Corridor	D9-19	2H.14	24 x 24	36 x 36
Alternative Fuels Corridor (1 line) (plaque)	D9-19aP	2H.14	30 x 9	42 x 12
Alternative Fuels Corridor (2 lines) (plaque)	D9-19bP	2H.14	30 x 12	42 x 18
Reference Location (1 digit)	D10-1	2H.11	10 x 18	12 x 24
Intermediate Reference Location (2 digits)	D10-1a	2H.11	10 x 27	12 x 36
Reference Location (2 digits)	D10-2	2H.11	10 x 27	12 x 36
Intermediate Reference Location (3 digits)	D10-2a	2H.11	10 x 36	12 x 48
Reference Location (3 digits)	D10-3	2H.11	10 x 36	12 x 48
Intermediate Reference Location (4 digits)	D10-3a	2H.11	10 x 48	12 x 60
Enhanced Reference Location	D10-4	2H.12	12 x 30 18 x 54 (O)	18 x 54
Intermediate Enhanced Reference Location	D10-5	2H.12	12 x 36 18 x 60 (O)	18 x 60
Traffic Signal Speed	I1-1	2H.04	24 x 36	—
Jurisdictional Boundary	I2-1	2H.05	Varies x 18** Varies x 24 (O)	Varies x 36** Varies x 42 (O)
Geographical Feature	I2-2	2H.06	Varies x 18** Varies x 24 (O)	Varies x 36**
Grade Separation Identification	I2-3	2H.10	—	Varies x 18
Grade Separation Identification (2 lines)	I2-3a	2H.10	—	Varies x 24
Future Interstate Corridor	I2-4	2H.08	54 x 36	72 x 48
Future I-XX Corridor	I2-4a	2H.08	48 x 36	66 x 48
Project Information	I2-5	2H.09	96 x 48	156 x 72
Airport	I3-5	2H.01	24 x 24	30 x 30
Bus Station	I3-6	2H.01	24 x 24	30 x 30
Train Station	I3-7	2H.01	24 x 24	30 x 30
Light Rail Transit Station	I3-8	2H.01	24 x 24	—
Vehicle Ferry Terminal	I3-9	2H.01	24 x 24	30 x 30
Passenger Only Ferry Terminal	I3-10	2H.01	24 x 24	30 x 30
Ferry (plaque)	I3-10P	2H.01	24 x 12	30 x 18
Library	I4-1	2H.01	24 x 24	—
Recycling Center	I4-2	2H.01	30 x 36	—
Acknowledgment	I20-1	2H.13	36 x 30*	72 x 48*
Acknowledgment	I20-2	2H.13	36 x 30*	72 x 48*
Acknowledgment	I20-3	2H.13	42 x 24*	96 x 36*
Acknowledgment - Rest Area	I20-4	2H.13	56 x 36*	72 x 48*
Acknowledgment - Welcome Center	I20-4a	2H.13	56 x 36*	72 x 48*
Acknowledgment (plaque)	I20-5P	2H.13	Varies x Varies***	Varies x Varies***
Last In Corridor (plaque)	W16-19P	2H.14	24 x 18	24 x 18

* The size shown is the maximum size for the corresponding roadway classification. The size of the sign and acknowledgment logo should be appropriately reduced where shorter legends are used.

** The size shown is for the typical sign illustrated in the figure. The size should be determined based on the number of lines of legend on the sign.

*** Limitations on the size of Acknowledgment plaques are provided in Section 2H.13.

Notes: 1. Larger signs may be used when appropriate, except for the I20 series signs and plaque

2. (O) denotes Oversized

3. Dimensions are in inches shown as width x height

MUTCD 11th Edition General Service



D5-1



D5-1a



D5-2

Specify Number



D5-2a



D5-5



D5-6

Specify Number

Note: Alternate legends may be substituted for the PICNIC AREA legend, such as ROADSIDE TABLE and ROADSIDE PARK, and for the SCENIC AREA legend, such as SCENIC VIEW and SCENIC OVERLOOK.



D5-9



D5-9a



D5-9b

Specify Number



D5-10



D5-10a



D5-10b

Specify Number



D5-11



D5-11a



D5-11b

Specify Number

MUTCD 11th Edition General Service



D9-1
Telephone



D9-2
Hospital



D9-3
Camping



D9-4
Litter Container



D9-6
International Symbol of Accessibility



D9-6P



D9-7
Gas



D9-8
Food



D9-9
Lodging



D9-10
Tourist Information



D9-11
Diesel Fuel



D9-11a
Alternative Fuel-
Compressed
Natural Gas



D9-11b
Electric Vehicle
Charging



D9-11bP
Electric Vehicle
Charging



D9-11c
Alternative Fuel-
Ethanol



D9-11d
Liquefied Natural
Gas (LNG)



D9-11e
Liquefied
Petroleum Gas
(LPG)

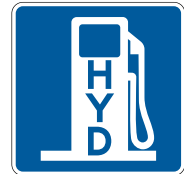

D9-11f
Hydrogen Fuel
(HYD)



D9-11g
Biofuel (BIO)



D9-12
RV Sanitary
Station



D9-13
Emergency
Medical Services



D9-13aP
Hospital



D9-13bP
Ambulance
Station



D9-13cP
Emergency
Medical Care



D9-13dP
Trauma Center



D9-14
Police



D9-16
Truck Parking



D9-16aP
Truck External
Power



D9-20
Pharmacy



D9-20aP
24-Hour



D9-21
Telecommunications
Device for the Deaf



D9-22
Wireless
Internet

Advance Turn and Directional Arrow auxiliary plaques for use with General Service signs



M5-1PL



M5-1PR



M5-2PL



M5-2PR



M5-3PL



M5-3PR



M6-1P



M6-2PL



M6-2PR



M6-3P



Example of
directional assembly

Table 2I-1. General Service Sign and Plaque Sizes (Sheet 1 of 2)

Sign or Plaque	Sign Designation	Section	Conventional Road	Freeway or Expressway
Rest Area Advance	D5-1	2I.05	78 x 36*	132 x 60* (F) 114 x 48* (E)
Rest Area Advance Direction	D5-1a	2I.05	78 x 36*	132 x 60* (F) 114 x 48* (E)
Rest Area Entrance Direction	D5-2	2I.05	78 x 36*	132 x 66* (F) 114 x 60 (E)
Rest Area Gore	D5-2a	2I.05	42 x 48*	78 x 78* (F) 66 x 72* (E)
Rest Area Directional	D5-5	2I.05	42 x 48*	—
Next Rest Area	D5-6	2I.05	78 x 54*	132 x 78* (F) 108 x 66* (E)
Rest Area Tourist Info Center Advance	D5-7	2I.08	90 x 72*	156 x 108* (F) 132 x 96* (E)
Rest Area Tourist Info Center Advance Direction	D5-7a	2I.08	90 x 72*	156 x 108* (F) 132 x 96* (E)
Rest Area Tourist Info Center Entrance Direction	D5-8	2I.08	84 x 72*	138 x 108* (F) 120 x 96* (E)
Parking Area Advance	D5-9	2I.05	96 x 36*	162 x 60* (F) 138 x 48* (E)
Parking Area Entrance Direction	D5-9a	2I.05	96 x 36*	162 x 60* (F) 138 x 54* (E)
Parking Area Gore	D5-9b	2I.05	62 x 48*	108 x 78* (F) 88 x 66* (E)
Picnic Area (Roadside Table, Roadside Park) Advance	D5-10	2I.05	84 x 36*	144 x 60* (F) 120 x 48* (E)
Picnic Area (Roadside Table, Roadside Park) Entrance Direction	D5-10a	2I.05	84 x 36*	144 x 60* (F) 120 x 54* (E)
Picnic Area (Roadside Table, Roadside Park) Gore	D5-10b	2I.05	54 x 48*	92 x 78* (F) 76 x 66* (E)
Scenic Area (Scenic View, Scenic Overlook) Advance	D5-11	2I.05	84 x 36*	144 x 60* (F) 120 x 48* (E)
Scenic Area (Scenic View, Scenic Overlook) Entrance Direction	D5-11a	2I.05	84 x 36*	144 x 60* (F) 120 x 54* (E)
Scenic Area (Scenic View, Scenic Overlook) Gore	D5-11b	2I.05	54 x 48*	92 x 78* (F) 76 x 66* (E)
Interstate Oasis	D5-12	2I.04	—	198 x 60 (F) 162 x 48 (E)
Interstate Oasis (plaque)	D5-12aP	2I.04	—	114 x 48
Interstate Oasis Directional	D5-12b	2I.04	—	48 x 36
Brake Check Area Advance	D5-13	2I.06	96 x 54	132 x 66
Brake Check Area Entrance Direction	D5-14	2I.06	96 x 54	132 x 78
Chain-Up Area Advance	D5-15	2I.07	72 x 54	102 x 66
Chain-Up Area Entrance Direction	D5-16	2I.07	72 x 54	102 x 78
Telephone	D9-1	2I.02	24 x 24	30 x 30
Hospital	D9-2	2I.02	24 x 24	30 x 30
Camping	D9-3	2I.02	24 x 24	30 x 30
Litter Container	D9-4	2I.02	24 x 30	36 x 48
International Symbol of Accessibility	D9-6	2I.02	24 x 24	30 x 30
Van Accessible (plaque)	D9-6P	2I.02	18 x 9	—
Gas	D9-7	2I.02	24 x 24	30 x 30
Food	D9-8	2I.02	24 x 24	30 x 30
Lodging	D9-9	2I.02	24 x 24	30 x 30
Tourist Information	D9-10	2I.02	24 x 24	30 x 30
Diesel Fuel	D9-11	2I.02	24 x 24	30 x 30
Alternative Fuel - Compressed Natural Gas	D9-11a	2I.02	24 x 24***	30 x 30***
Electric Vehicle Charging	D9-11b	2I.02	24 x 24***	30 x 30***
Electric Vehicle Charging (plaque)	D9-11bP	2I.02	24 x 18	30 x 24
Alternative Fuel - Ethanol	D9-11c	2I.02	24 x 24	30 x 30

Table 2I-1. General Service Sign and Plaque Sizes (Sheet 2 of 2)

Sign or Plaque	Sign Designation	Section	Conventional Road	Freeway or Expressway
Alternative Fuel - Liquefied Natural Gas	D9-11d	2I.02	24 x 24***	30 x 30***
Alternative Fuel - Liquefied Petroleum Gas	D9-11e	2I.02	24 x 24***	30 x 30***
Alternative Fuel - Hydrogen	D9-11f	2I.02	24 x 24***	30 x 30***
Alternative Fuel - Biofuel	D9-11g	2I.02	24 x 24	30 x 30
RV Sanitary Station	D9-12	2I.02	24 x 24	30 x 30
Emergency Medical Services	D9-13	2I.02	24 x 24	30 x 30
Hospital (plaque)	D9-13aP	2I.02	24 x 12	30 x 12
Ambulance Station (plaque)	D9-13bP	2I.02	24 x 12	30 x 15
Emergency Medical Care (plaque)	D9-13cP	2I.02	24 x 18	30 x 24
Trauma Center (plaque)	D9-13dP	2I.02	24 x 12	30 x 15
Police	D9-14	2I.02	24 x 24	30 x 30
Truck Parking	D9-16	2I.03	24 x 24	30 x 30
Truck External Power (plaque)	D9-16aP	2I.03	24 x 24	30 x 30
Truck Parking Availability - Exit Number	D9-16b	2I.15	Varies x 144	Varies x 144
Truck Parking Availability - Distance	D9-16c	2I.15	Varies x 144	Varies x 144
Truck Parking Availability - Rest Area	D9-16d	2I.15	Varies x Varies	Varies x Varies
Truck Parking Availability - Combined	D9-16e	2I.15	Varies x Varies	Varies x Varies
Next Services Advance (plaque)	D9-17P	2I.02	72 x 24	114 x 30
Next EV Charging	D9-17a	2H, 2J	—	126 x 60
General Services (up to 6 symbols) with Exit Number	D9-18	2I.03	108 x 84	132 x 114 (F) 132 x 108 (E)
General Services with Exit Number	D9-18a	2I.03	72 x 60	132 x 108** (F) 102 x 84** (E)
General Services (up to 6 symbols) with Action Message	D9-18b	2I.03	108 x 84	132 x 114 (F) 132 x 108 (E)
General Services with Action Message	D9-18c	2I.03	72 x 60**	132 x 108** (F) 102 x 84** (E)
Rural Interchange General Services (up to 3 symbols) (plaque)	D9-18dP	2I.03	—	120 x 36
Rural Interchange General Services (1 line) (plaque)	D9-18eP	2I.03	—	Varies x 24
Rural Interchange General Services (2 line) (plaque)	D9-18fP	2I.03	—	Varies x 42
Pharmacy	D9-20	2I.02	24 x 24	30 x 30
24-Hour (plaque)	D9-20aP	2I.02	24 x 12	30 x 12
Telecommunications Device for the Deaf	D9-21	2I.02	24 x 24	30 x 30
Wireless Internet	D9-22	2I.02	24 x 24	30 x 30
Radio - Weather Information	D12-1	2I.09	84 x 48	132 x 84
Radio - Traffic Information	D12-1a	2I.09	96 x 48	120 x 60
Urgent Message When Flashing (plaque)	D12-1bP	2I.09	84 x 30	108 x 36
Carpool Information	D12-2	2I.14	60 x 42	96 x 66
Channel 9 Monitored	D12-3	2I.10	84 x 48	132 x 84
Emergency Call 911	D12-4	2I.11	66 x 30	96 x 48
Travel Info Call 511 (pictograph)	D12-5	2I.12	48 x 60	66 x 72
Travel Info Call 511	D12-5a	2I.12	48 x 36	66 x 48
Roadside Assistance	D12-6	2I.13	60 x 42	78 x 54

* The size shown is for a sign with a REST AREA, PARKING AREA, PICNIC AREA, SCENIC AREA, and/or TOURIST INFO CENTER legend. The size should be appropriately adjusted if an alternate legend is used.

** The size shown is for a sign with four lines of services. The size should be appropriately adjusted depending on the amount of legend displayed.

*** The Standard Highway Signs publication contains layouts for the 18 x 18-inch and 24 x 24-inch alternative fuels symbol signs mounted with the Alternative Fuels Corridor sign in accordance with Section 2H.14.

Notes: 1. Larger signs may be used when appropriate.

2. Dimensions in inches are shown as width x height

3. Where two sizes are shown, the larger size is for freeways (F) and the smaller size is for expressways (E)

MUTCD 11th Edition School Area

* If used, the assembly or sign with WHEN FLASHING legend shall be accompanied by a flashing yellow Speed Limit Sign Beacon

School Advance Crossing Assembly

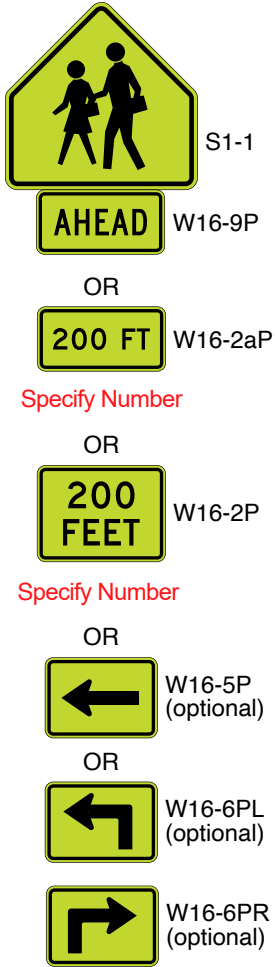

School Crossing Assembly

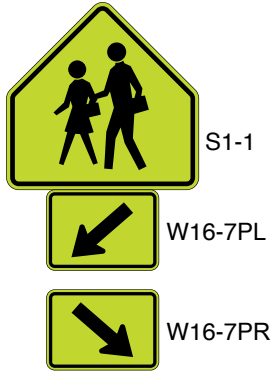

School Zone Sign

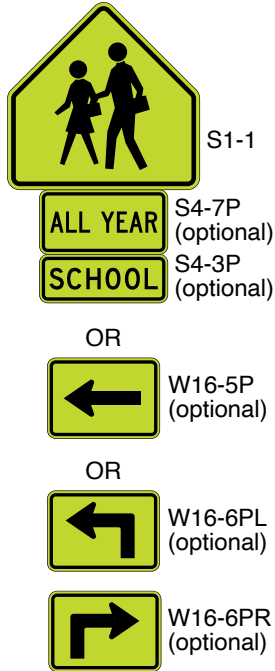

School Speed Limit Assembly

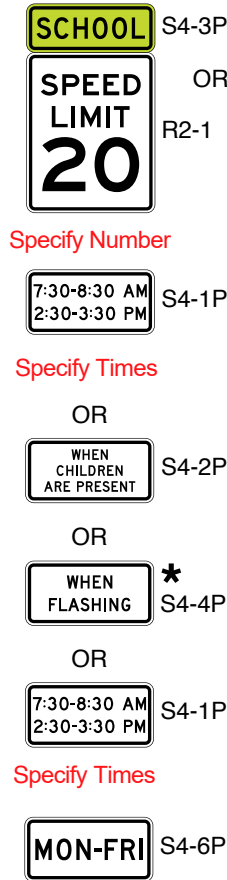

School Speed Limit When Flashing Sign

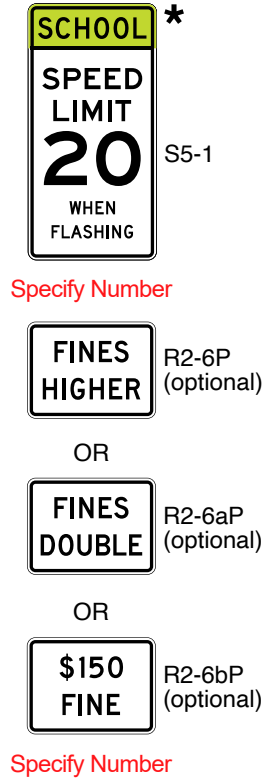

S3-1



S3-2



S4-5

Specify Number



S4-5a

Specify Number

MUTCD 11th Edition School Area

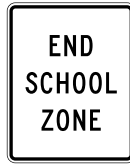

S5-2

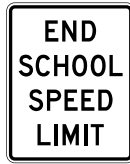

S5-3



R2-10

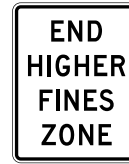

R2-11



R1-5aL



R1-5aR



R1-5cL



R1-5cR

In-Street Use



S1-1*

W16-9P*

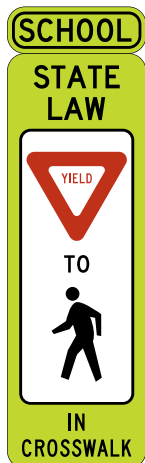

R1-6

S4-3P*

OR



R1-6a

S4-3P*

OR



R1-6b

OR



R1-6c

OR



S1-1*

W16-7PL*

W16-7PR*

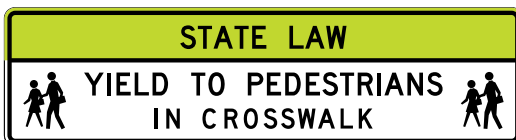

R1-9b (shown reduced 50% proportional to other signs on page)

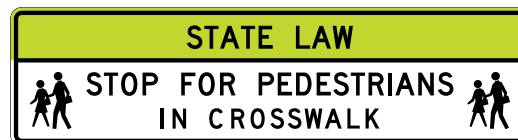

R1-9c (shown reduced 50% proportional to other signs on page)

Notes:

1. The use of the STATE LAW legend is optional on the R1-6 series and R1-9 series signs (see Section 7B.03).
2. The use of the SCHOOL plaque above the R1-6 and R1-6a signs is optional.
3. Signs are shown in proportion to their designated sizes unless otherwise noted.

*Reduced size signs for in-street use (see Section 7B.03):

S1-1	12 x 12 inches
S4-3P	12 x 4 inches
W16-7P	12 x 6 inches
W16-9P	12 x 6 inches

Table 7B-1. School Area Sign and Plaque Sizes

Sign	Sign Designation	Section	Conventional Road	Minimum	Oversized
School	S1-1	7B.02	36 x 36	30 x 30	48 x 48
School Bus Stop Ahead	S3-1	7B.04	36 x 36	30 x 30	48 x 48
School Bus Turn Ahead	S3-2	7B.04	36 x 36	30 x 30	48 x 48
Reduced School Speed Limit Ahead	S4-5, S4-5a	7B.05	36 x 36	30 x 30	48 x 48
School Speed Limit XX When Flashing	S5-1	7B.05	24 x 48	—	36 x 72
End School Zone	S5-2	7B.02	24 x 30	—	36 x 48
End School Speed Limit	S5-3	7B.05	24 x 30	—	36 x 48
Yield (Stop) Here for School Crossing	R1-5a, R1-5c	7B.03	36 x 36	—	—
In-Street Ped or School Crossing	R1-6, R1-6a, R1-6b, R1-6c	7B.03	12 x 36	—	—
Overhead School Crossing	R1-9b, R1-9c	7B.03	90 x 24	—	—
Speed Limit (School Use)	R2-1	7B.05	24 x 30	—	36 x 48
Begin Higher Fines Zone	R2-10	7B.06	24 x 30	—	36 x 48
End Higher Fines Zone	R2-11	7B.06	24 x 30	—	36 x 48

Plaque	Sign Designation	Section	Conventional Road	Minimum	Oversized
Time of Day X:XX to X:XX AM X:XX to X:XX PM	S4-1P	7B.06	24 x 12	—	36 x 18
When Children Are Present	S4-2P	7B.06	24 x 12	—	36 x 18
School	S4-3P	7B.02, 7B.05	24 x 9	—	36 x 12
When Flashing	S4-4P	7B.05, 7B.06	24 x 12	—	36 x 18
Days of Week Mon-Fri	S4-6P	7B.05	24 x 12	—	36 x 18
All Year	S4-7P	7B.02	24 x 12	—	30 x 18
Fines Higher	R2-6P	7B.06	24 x 18	—	36 x 24
Fines Double	R2-6aP	7B.06	24 x 18	—	36 x 24
\$XX Fine	R2-6bP	7B.06	24 x 18	—	36 x 24
XX Feet (2-line)	W16-2P	7B.02, 7B.03	24 x 18	—	30 x 24
XX Ft (1-line)	W16-2aP	7B.02, 7B.03	24 x 12	—	30 x 18
Directional Arrow	W16-5P	7B.02, 7B.03	21 x 15	—	30 x 21
Advance Turn Arrow	W16-6P	7B.02, 7B.03	21 x 15	—	30 x 21
Downward Diagonal Arrow	W16-7P	7B.02, 7B.03	21 x 15	—	30 x 21
Ahead	W16-9P	7B.02, 7B.03	24 x 12	—	30 x 18

- Notes: 1. Larger sizes may be used when appropriate
 2. Dimensions are shown in inches and are shown as width x height
 3. Minimum sign sizes for multi-lane conventional roads shall be as shown in the Conventional Road column

MUTCD 11th Edition Warning

Turn Symbol

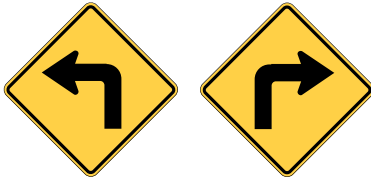

W1-1L

W1-1R

Curve Symbol

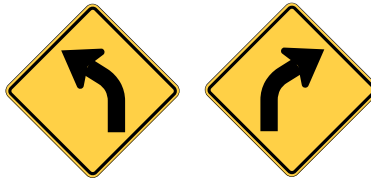

W1-2L

W1-2R

Reverse Turn Symbol

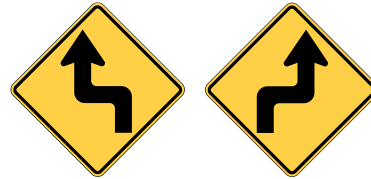

W1-3L

W1-3R

Reverse Curve Symbol

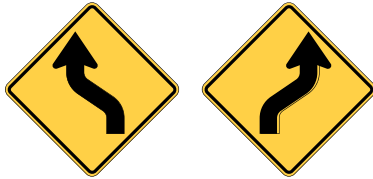

W1-4L

W1-4R

Winding Road Symbol



W1-5L

W1-5R



W1-6



W1-7

Note: Turn arrows and reverse turn arrows may be substituted for the curve arrows and reverse curve arrows on the W1-10 series signs where appropriate.



W1-8



W1-10L



W1-10R



W1-10aL



W1-10aR



W1-10bL



W1-10bR



W1-10cL



W1-10cR



W1-10dL



W1-10dR



W1-10eL



W1-10eR



W1-11



W1-13



W1-15



W13-1P



W13-1aP



W13-2

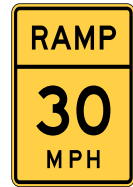

W13-3

Specify Number

Specify Number



W3-1



W3-2



W3-3



W3-4



W3-6

MUTCD 11th Edition Warning



W23-2



W23-2a



W26-1



W3-5

Specify Number



W3-5a



W3-5b



W3-5c

Specify Number



W2-1



W2-2



W2-3L



W2-3R



W2-3aL



W2-3aR



W2-4



W2-5



W2-6



W16-12P
(optional)

OR



W16-12aP
(optional)



W2-7L



W2-7R



W2-8



W2-10



W2-11



W4-4P



W4-4aP



W4-4bP



W25-1



W25-2

MUTCD 11th Edition Warning



W4-1L



W4-1R



W4-2L



W4-2R



W4-3L



W4-3R



W4-5L



W4-5R



W4-5aP



W4-6L



W4-6R



W4-7L



W4-7R



W4-8



W6-3



W6-5



W6-5a



W8-26

Specify Number



W8-26a

Specify Number



W9-1L



W9-1R



W9-4



W14-3



W5-1



W5-2



W5-2a



W5-3



W5-3a



W6-1



W6-2



W12-1



W12-2

Specify Numbers



W12-2a



W12-2b

MUTCD 11th Edition Warning



W14-1



W14-1a



W14-1a



W14-2



W14-2a



W14-2a



W18-1



W7-1



W7-1a

Specify Number



W7-2P



W7-2bP



W7-3P

Specify Number



W7-3aP

Specify Number



W7-3bP

Specify Number

B. 6% grade that is more than 2,000 feet in length,
 C. 7% grade that is more than 1,000 feet in length,
 D. 8% grade that is more than 750 feet in length, or
 E. 9% grade that is more than 500 feet in length.



W7-4dP



W7-4eP



W7-4fP

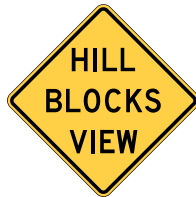

W7-6



W8-1



W8-2



W8-3



W8-4



W8-5



W8-5P



W8-5bP



W8-5aP



W8-5cP



W8-6



W8-7



W8-8



W8-9



W8-11



W8-12



W8-14



W8-15



W8-16



W8-17



W8-13



W8-15aP (optional)



W8-15aP (optional)



W8-17P (optional)

MUTCD 11th Edition Warning

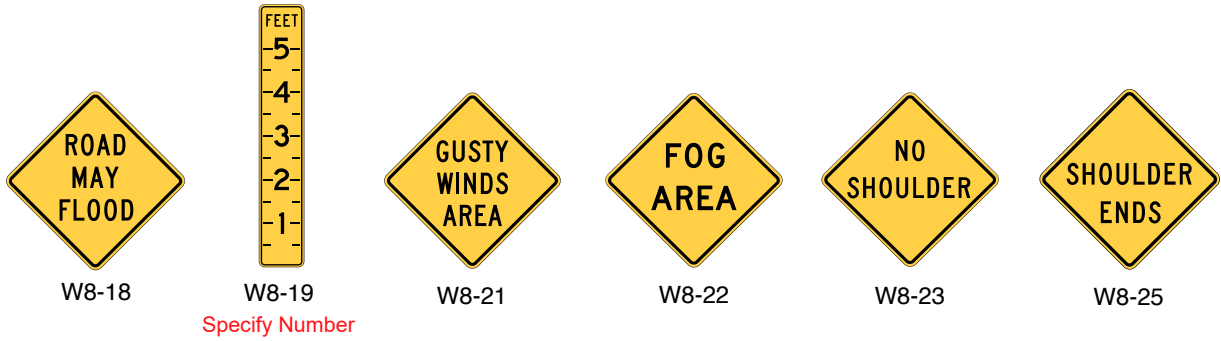

A fluorescent yellow-green background color may be used for this sign or plaque.

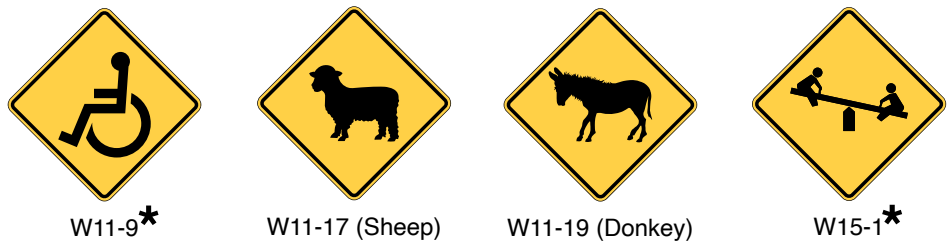

MUTCD 11th Edition Warning

Note: The background color (yellow or fluorescent yellow-green) shall match the color of the warning sign that it supplements.

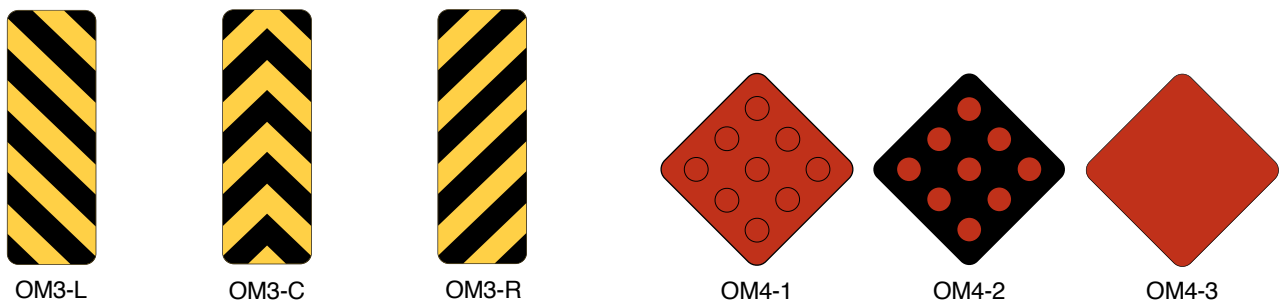
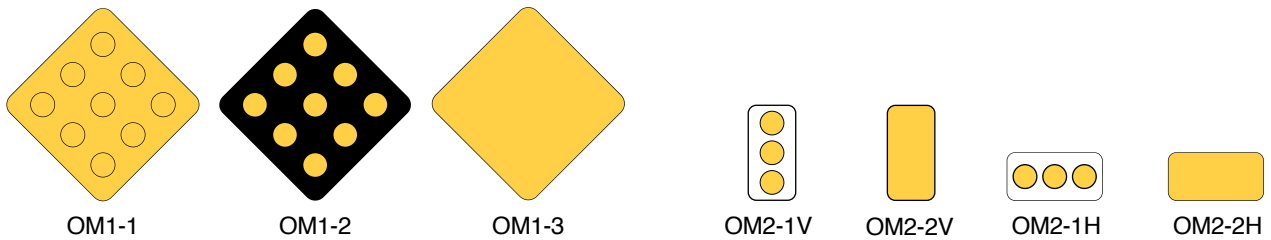
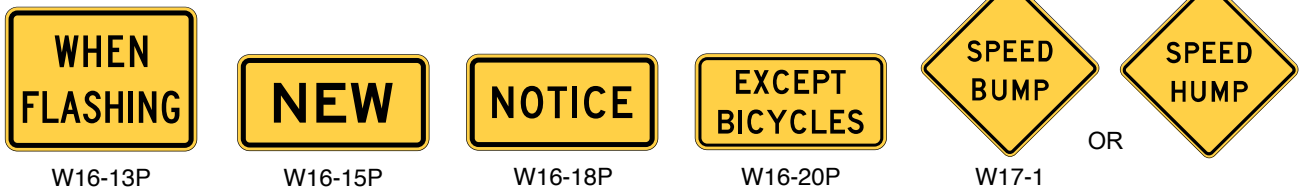
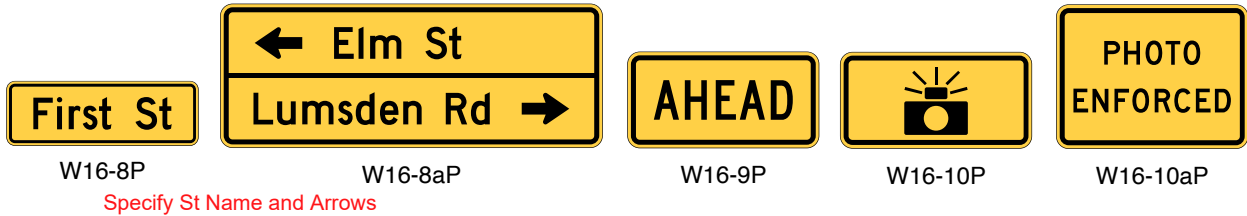
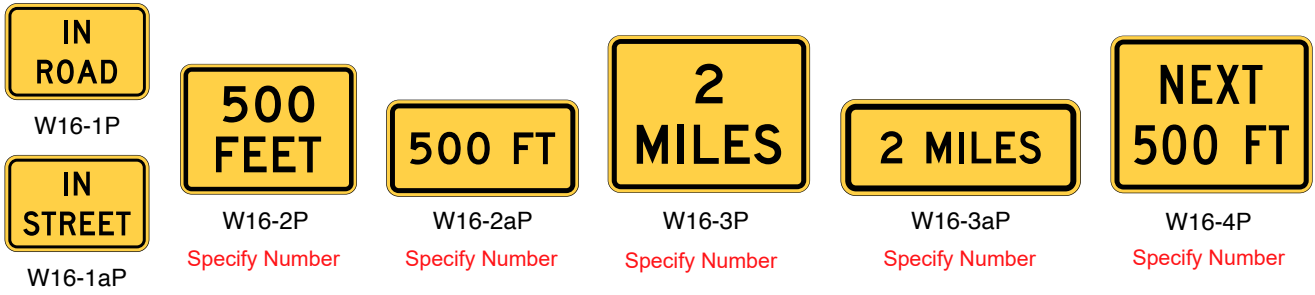

Table 2C-1. Warning Sign and Plaque Sizes (Sheet 1 of 4)

Sign or Plaque	Sign Designation	Section	Conventional Road		Expressway	Freeway	Minimum	Oversized
			Single Lane	Multi-Lane				
Horizontal Alignment	W1-1,2,3,4,5	2C.07	30 x 30*	36 x 36	36 x 36	36 x 36	—	48 x 48
One-Direction Large Arrow	W1-6	2C.10	48 x 24	48 x 24	60 x 30	60 x 30	—	60 x 30
Two-Direction Large Arrow	W1-7	2C.43	48 x 24	48 x 24	—	—	—	60 x 30
Chevron Alignment	W1-8	2C.08	18 x 24	18 x 24	30 x 36	36 x 48	—	24 x 30
Combination Horizontal Alignment/Intersection	W1-10,10a,10b,10c,10d,10e	2C.09	36 x 36	36 x 36	36 x 36	48 x 48	—	—
Hairpin Curve	W1-11	2C.07	30 x 30	30 x 30	36 x 36	48 x 48	—	48 x 48
Truck Rollover	W1-13	2C.11	36 x 36	36 x 36	36 x 36	48 x 48	—	48 x 48
270-degree Curve	W1-15	2C.07	30 x 30	30 x 30	36 x 36	48 x 48	—	48 x 48
Intersection Warning	W2-1,2,3,3a,4,5,6,7,8	2C.41	30 x 30	30 x 30	36 x 36	—	24 x 24	48 x 48
Traffic Entering When Flashing	W2-10	2C.42	36 x 36	36 x 36	48 x 48	—	—	—
Traffic Approaching When Flashing	W2-11	2C.42	36 x 36	36 x 36	48 x 48	—	—	—
Stop, Yield, Signal Ahead	W3-1,2,3	2C.35	30 x 30	30 x 30	48 x 48	48 x 48	30 x 30	—
Be Prepared to Stop	W3-4	2C.35	36 x 36	36 x 36	48 x 48	48 x 48	30 x 30	—
Reduced Speed Limit Ahead	W3-5	2C.40	36 x 36	36 x 36	48 x 48	48 x 48	—	—
XX MPH Speed Zone Ahead	W3-5a	2C.40	36 x 36	36 x 36	48 x 48	48 x 48	—	—
Variable Speed Zone Ahead	W3-5b	2C.40	36 x 36	36 x 36	48 x 48	48 x 48	—	—
XX MPH Truck Speed Zone Ahead	W3-5c	2C.40	36 x 36	36 x 36	48 x 48	48 x 48	—	—
Draw Bridge	W3-6	2C.36	36 x 36	36 x 36	48 x 48	—	—	60 x 60
Ramp Meter Ahead	W3-7	2C.37	36 x 36	36 x 36	—	—	—	—
Ramp Metered When Flashing	W3-8	2C.37	36 x 36	36 x 36	—	—	—	—
Merge	W4-1	2C.45	36 x 36	36 x 36	48 x 48	48 x 48	30 x 30*	—
Lane Ends	W4-2	2C.47	36 x 36	36 x 36	48 x 48	48 x 48	30 x 30*	—
Added Lane	W4-3	2C.46	36 x 36	36 x 36	48 x 48	48 x 48	30 x 30*	—
Cross Traffic Does Not Stop (plaque)	W4-4P	2C.66	24 x 12	24 x 12	36 x 18	—	—	48 x 24
Traffic From Left (Right) Does Not Stop (plaque)	W4-4aP	2C.66	24 x 12	24 x 12	36 x 18	—	—	48 x 24
Oncoming Traffic Does Not Stop (plaque)	W4-4bP	2C.66	24 x 12	24 x 12	36 x 18	—	—	48 x 24
Entering Roadway Merge	W4-5	2C.45	36 x 36	36 x 36	48 x 48	48 x 48	—	—
No Merge Area (plaque)	W4-5aP	2C.45	18 x 24	18 x 24	24 x 30	24 x 30	—	—
Entering Roadway Added Lane	W4-6	2C.46	36 x 36	36 x 36	48 x 48	48 x 48	—	—
Heavy Merge from Right (Left)	W4-7	2C.49	36 x 36	36 x 36	48 x 48	48 x 48	—	—
Single Lane Transition	W4-8	2C.48	36 x 36	36 x 36	36 x 36	48 x 48	—	48 x 48
Road Narrows	W5-1	2C.17	36 x 36	36 x 36	48 x 48	48 x 48	30 x 30*	—
Narrow Bridge	W5-2	2C.18	36 x 36	36 x 36	48 x 48	48 x 48	30 x 30*	—
Narrow Underpass	W5-2a	2C.18	36 x 36	36 x 36	48 x 48	48 x 48	30 x 30*	—
One Lane Bridge	W5-3	2C.19	36 x 36	36 x 36	48 x 48	48 x 48	30 x 30*	—
One Lane Underpass	W5-3a	2C.19	36 x 36	36 x 36	48 x 48	48 x 48	30 x 30*	—
Divided Highway	W6-1	2C.20	36 x 36	36 x 36	48 x 48	48 x 48	—	—
Divided Highway Ends	W6-2	2C.21	36 x 36	36 x 36	48 x 48	48 x 48	—	—
Two-Way Traffic	W6-3	2C.51	36 x 36	36 x 36	48 x 48	48 x 48	—	—
Two-Way Traffic (3-Lane)	W6-5	2C.52	36 x 36	36 x 36	48 x 48	—	—	—
Two-Way Traffic (3-Lane)	W6-5a	2C.52	36 x 36	36 x 36	48 x 48	—	—	—
Hill	W7-1	2C.14	30 x 30*	36 x 36	36 x 36	36 x 36	24 x 24*	48 x 48
Hill with Grade	W7-1a	2C.14	30 x 30*	36 x 36	36 x 36	36 x 36	24 x 24*	48 x 48

Table 2C-1. Warning Sign and Plaque Sizes (Sheet 2 of 4)

Sign or Plaque	Sign Designation	Section	Conventional Road		Expressway	Freeway	Minimum	Oversized
			Single Lane	Multi-Lane				
Use Low Gear (plaque)	W7-2P	2C.64	24 x 18	24 x 18	—	—	—	—
Trucks Use Lower Gear (plaque)	W7-2bP	2C.64	24 x 18	24 x 18	—	—	—	—
XX% Grade (plaque)	W7-3P	2C.64	24 x 18	24 x 18	—	—	—	—
Next XX Miles (plaque)	W7-3aP	2C.61	24 x 18	24 x 18	—	—	—	—
XX% Grade, XX Miles (plaque)	W7-3bP	2C.64	24 x 18	24 x 18	—	—	—	—
Runaway Truck Ramp XX Miles	W7-4	2C.15	84 x 48	84 x 48	120 x 72	120 x 72	—	—
Runaway Truck Ramp Entrance Direction	W7-4b	2C.15	84 x 54	84 x 54	120 x 78	120 x 78	—	—
Truck Escape Ramp	W7-4c	2C.15	78 x 60	78 x 60	78 x 60	78 x 60	—	—
Sand, Gravel, Paved (plaques)	W7-4dP, 4eP, 4fP	2C.15	24 x 12	24 x 12	24 x 12	24 x 12	—	—
Hill Blocks View	W7-6	2C.16	30 x 30*	36 x 36	36 x 36	—	—	48 x 48
Bump or Dip	W8-1,2	2C.26	30 x 30*	36 x 36	36 x 36	48 x 48	24 x 24*	48 x 48
Pavement Ends	W8-3	2C.28	36 x 36	36 x 36	48 x 48	—	30 x 30*	—
Soft Shoulder	W8-4	2C.29	36 x 36	36 x 36	48 x 48	48 x 48	24 x 24*	48 x 48
Slippery When Wet	W8-5	2C.30	30 x 30*	36 x 36	36 x 36	48 x 48	24 x 24*	48 x 48
Road Condition (plaques)	W8-5P,5bP,5cP	2C.30	24 x 18	24 x 18	30 x 24	36 x 30	—	36 x 30
Ice (plaque)	W8-5aP	2C.30	24 x 12	24 x 12	30 x 18	30 x 18	—	—
Truck Crossing	W8-6	2C.54	36 x 36	36 x 36	36 x 36	48 x 48	24 x 24*	48 x 48
Loose Gravel	W8-7	2C.30	36 x 36	36 x 36	36 x 36	—	24 x 24*	48 x 48
Rough Road	W8-8	2C.30	36 x 36	36 x 36	36 x 36	48 x 48	24 x 24*	48 x 48
Low Shoulder	W8-9	2C.29	36 x 36	36 x 36	36 x 36	48 x 48	24 x 24*	48 x 48
Uneven Lanes	W8-11	2C.30	36 x 36	36 x 36	36 x 36	48 x 48	—	48 x 48
No Center Line	W8-12	2C.32	36 x 36	36 x 36	36 x 36	48 x 48	—	—
Bridge Ices Before Road	W8-13	2C.30	36 x 36	36 x 36	36 x 36	48 x 48	24 x 24*	48 x 48
Fallen Rocks	W8-14	2C.30	30 x 30*	36 x 36	36 x 36	48 x 48	24 x 24*	48 x 48
Grooved Pavement	W8-15	2C.31	30 x 30*	36 x 36	36 x 36	48 x 48	24 x 24*	48 x 48
Motorcycle (plaque)	W8-15aP	2C.31	24 x 18	24 x 18	30 x 24	36 x 30	—	36 x 30
Metal Bridge Deck	W8-16	2C.31	30 x 30*	36 x 36	36 x 36	48 x 48	24 x 24*	48 x 48
Shoulder Drop-Off	W8-17	2C.29	30 x 30*	36 x 36	36 x 36	48 x 48	24 x 24*	48 x 48
Shoulder Drop-Off (plaque)	W8-17P	2C.29	24 x 18	24 x 18	30 x 24	36 x 30	—	36 x 30
Road May Flood	W8-18	2C.34	36 x 36	36 x 36	36 x 36	48 x 48	24 x 24*	48 x 48
Depth Gauge	W8-19	2C.34	12 x 72	12 x 72	—	—	—	—
Gusty Winds Area	W8-21	2C.34	36 x 36	36 x 36	36 x 36	48 x 48	24 x 24*	48 x 48
Fog Area	W8-22	2C.34	36 x 36	36 x 36	36 x 36	48 x 48	24 x 24*	48 x 48
No Shoulder	W8-23	2C.29	36 x 36	36 x 36	36 x 36	48 x 48	24 x 24*	48 x 48
Shoulder Ends	W8-25	2C.29	30 x 30*	36 x 36	36 x 36	48 x 48	24 x 24*	48 x 48
Road Ends	W8-26	2C.24	30 x 30	36 x 36	—	—	—	—
Street Ends	W8-26a	2C.24	30 x 30	36 x 36	—	—	—	—
Right (Left) Lane Ends	W9-1	2C.47	36 x 36	36 x 36	36 x 36	48 x 48	30 x 30*	48 x 48
Lanes Merge	W9-4	2C.48	36 x 36	36 x 36	36 x 36	48 x 48	30 x 30*	48 x 48
Right (Left) Lane for Exit Only	W9-7	2C.50	132 x 72	132 x 72	132 x 72	132 x 72	—	—
Bicycle	W11-1	2C.54	30 x 30	30 x 30	36 x 36	—	—	48 x 48
Pedestrian	W11-2	2C.55	30 x 30*	36 x 36	36 x 36	—	—	48 x 48
Large Animals	W11-3,4,16,17, 18,19,20,21,22	2C.55	30 x 30*	36 x 36	36 x 36	—	24 x 24*	48 x 48
Farm Vehicle	W11-5	2C.54	30 x 30*	36 x 36	36 x 36	—	24 x 24*	48 x 48
Snowmobile	W11-6	2C.55	30 x 30*	36 x 36	36 x 36	—	24 x 24*	48 x 48
Equestrian	W11-7	2C.55	30 x 30*	36 x 36	36 x 36	—	24 x 24*	48 x 48

Table 2C-1. Warning Sign and Plaque Sizes (Sheet 3 of 4)

Sign or Plaque	Sign Designation	Section	Conventional Road		Expressway	Freeway	Minimum	Oversized
			Single Lane	Multi-Lane				
Emergency Vehicle	W11-8	2C.54	30 x 30*	36 x 36	36 x 36	—	24 x 24*	48 x 48
Handicapped	W11-9	2C.55	30 x 30*	36 x 36	36 x 36	—	—	48 x 48
Truck	W11-10	2C.54	30 x 30*	36 x 36	36 x 36	—	24 x 24*	48 x 48
Golf Cart	W11-11	2C.54	30 x 30*	36 x 36	36 x 36	—	24 x 24*	48 x 48
Emergency Signal Ahead (plaque)	W11-12P	2C.54	36 x 30	36 x 30	36 x 30	—	—	—
Horse-Drawn Vehicle	W11-14	2C.54	30 x 30*	36 x 36	36 x 36	—	24 x 24*	48 x 48
Trail Crossing	W11-15	2C.54	30 x 30*	36 x 36	36 x 36	—	24 x 24*	48 x 48
Trail Crossing	W11-15a	2C.54	30 x 30*	36 x 36	36 x 36	—	24 x 24*	48 x 48
Trail Crossing (plaque)	W11-15P	2C.54	24 x 18	24 x 18	30 x 24	—	—	36 x 30
Double Arrow	W12-1	2C.23	30 x 30*	36 x 36	36 x 36	—	—	—
Low Clearance Advance	W12-2	2C.25	36 x 36	36 x 36	48 x 48	48 x 48	30 x 30*	—
Low Clearance Overhead	W12-2a	2C.25	84 x 24	84 x 24	84 x 24	84 x 24	—	—
Low Clearance - Lane Overhead	W12-2b	2C.25	102 x 24	102 x 24	102 x 24	102 x 24	—	—
Advisory Speed (plaque)	W13-1P	2C.59	18 x 18	18 x 18	24 x 24	30 x 30	—	30 x 30
Advisory Speed Confirmation (plaque)	W13-1aP	2C.59	48 x 15	48 x 15	60 x 18	60 x 18	48 x 15	72 x 24
Advisory Exit or Ramp Speed	W13-2,3	2C.12	24 x 30	24 x 30	36 x 48	36 x 48	—	48 x 60
Combination Horizontal Alignment/Advisory Exit or Ramp Speed Loop	W13-6,7,8,9	2C.12	24 x 42	24 x 42	36 x 66	36 x 66	—	48 x 84
Combination Horizontal Alignment/Advisory Exit or Ramp Speed Turn	W13-10,11	2C.12	24 x 36	24 x 36	36 x 54	36 x 54	—	48 x 72
Combination Horizontal Alignment/Advisory Exit or Ramp Speed - Truck Rollover	W13-12,13	2C.12	24 x 42	24 x 42	36 x 66	36 x 66	—	48 x 84
Vehicle Speed Feedback Sign	W13-20	2C.13	24 x 30	30 x 36	36 x 48	48 x 60	—	—
Vehicle Speed Feedback (plaque)	W13-20aP	2C.13	24 x 18	30 x 24	36 x 30	48 x 36	—	—
Dead End, No Outlet	W14-1,2	2C.24	30 x 30*	36 x 36	36 x 36	—	24 x 24*	48 x 48
Dead End, No Outlet (with arrow)	W14-1a,2a	2C.24	36 x 9	36 x 9	—	—	—	—
No Passing Zone	W14-3	2C.53	48 x 48 x 36	48 x 48 x 36	64 x 64 x 48	64 x 64 x 48	40 x 40 x 30	64 x 64 x 48
Playground	W15-1	2C.56	30 x 30*	36 x 36	36 x 36	—	24 x 24*	48 x 48
In Road (plaque)	W16-1P	2C.67	18 x 12	18 x 12	24 x 18	—	—	24 x 18
In Street (plaque)	W16-1aP	2C.67	18 x 12	18 x 12	24 x 18	—	—	24 x 18
XX Feet (2-line plaque)	W16-2P	2C.61	24 x 18	24 x 18	30 x 24	30 x 24	—	30 x 24
XX Ft (1-line plaque)	W16-2aP	2C.61	24 x 12	24 x 12	—	—	—	30 x 18
XX Miles (2-line plaque)	W16-3P	2C.61	30 x 24	30 x 24	—	—	—	—
XX Miles (1-line plaque)	W16-3aP	2C.61	30 x 12	30 x 12	—	—	—	—
Next XX Feet (plaque)	W16-4P	2C.61	30 x 24	30 x 24	—	—	—	—
Supplemental Arrow (plaque)	W16-5P,6P	2C.62	21 x 15	21 x 15	—	—	—	30 x 21
Diagonal Downward Arrow (plaque)	W16-7P	2C.63	21 x 15	21 x 15	—	—	—	30 x 21
Dual Downward Diagonal Arrow (plaque)	W16-7aP	2C.63	21 x 15	21 x 15	—	—	—	30 x 21
Advance Street Name (1-line plaque)	W16-8P	2C.65	Varies x 8	Varies x 8	—	—	—	—
Advance Street Name (2-line plaque)	W16-8aP	2C.65	Varies x 15	Varies x 15	—	—	—	—
Ahead (plaque)	W16-9P	2C.55	24 x 12	24 x 12	30 x 18	—	—	30 x 18
Photo Enforced (symbol plaque)	W16-10P	2C.69	24 x 12	24 x 12	36 x 18	—	—	48 x 24
Photo Enforced (plaque)	W16-10aP	2C.69	24 x 18	24 x 18	36 x 30	—	—	48 x 36

Table 2C-1. Warning Sign and Plaque Sizes (Sheet 4 of 4)

Sign or Plaque	Sign Designation	Section	Conventional Road		Expressway	Freeway	Minimum	Oversized
			Single Lane	Multi-Lane				
Traffic Circle (plaque)	W16-12P	2C.41	24 x 18	24 x 18	—	—	—	—
Roundabout (plaque)	W16-12aP	2C.41	24 x 12	24 x 12	—	—	—	—
When Flashing (plaque)	W16-13P	2C.55	24 x 18	24 x 18	—	—	—	—
New (plaque)	W16-15P	2C.60	24 x 12	24 x 12	—	—	—	—
Notice (plaque)	W16-18P	2A.11	24 x 12	24 x 12	—	—	—	—
Except Bicycles (plaque)	W16-20P	2C.68	24 x 12	24 x 12	—	—	—	—
Speed Hump	W17-1	2C.27	30 x 30*	36 x 36	—	—	24 x 24*	48 x 48
No Traffic Signs	W18-1	2C.33	30 x 30*	36 x 36	—	—	24 x 24*	36 x 36
Freeway Ends XX Miles	W19-1	2C.22	—	—	—	144 x 48	—	—
Expressway Ends XX Miles	W19-2	2C.22	—	—	144 x 48	—	—	—
Freeway Ends	W19-3	2C.22	—	—	—	48 x 48	—	—
Expressway Ends	W19-4	2C.22	—	—	48 x 48	—	—	—
All Traffic Must Exit	W19-5	2C.22	—	—	90 x 48	90 x 48	—	—
New Traffic Pattern Ahead	W23-2	2C.38	36 x 36	36 x 36	—	—	—	—
New Signal Operation Ahead	W23-2a	2C.38	36 x 36	36 x 36	48 x 48	48 x 48	—	—
Oncoming Traffic Has (May Have) Extended Green	W25-1,2	2C.44	24 x 30	24 x 30	—	—	—	—
Watch for Stopped Traffic	W26-1	2C.39	36 x 36	36 x 36	48 x 48	48 x 48	—	—

* The minimum size required for diamond-shaped warning signs facing traffic on multi-lane conventional roads shall be 36 x 36 per Section 2C.03

Notes:

1. Larger signs may be used when appropriate
2. Dimensions are shown as width x height, in inches

Table 2C-2. Minimum Size of Supplemental Warning Plaques

Size of Warning Sign	Size of Supplemental Plaque			
	Rectangular			Square
	1 Line	2 Lines	Arrow	
24 x 24	24 x 12	24 x 18	21 x 15	18 x 18
30 x 30				
36 x 36	30 x 18	30 x 24	30 x 21	24 x 24
48 x 48				

Notes:

1. Larger supplemental plaques may be used when appropriate
2. Dimensions are shown as width x height, in inches

MUTCD 11th Edition Grade Crossing



R1-1



R1-2



R3-1a
Activated Blank-Out



R3-2a
Activated Blank-Out



R8-8



R8-9



R8-10L



R8-10R



R8-10aL



R8-10aR



R10-6L



R10-6R



R10-6aL



R10-6aR



R15-1



R10-10bL



R10-10bR

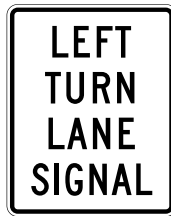

R10-10cL

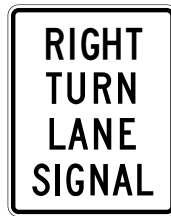

R10-10cR



R15-2P



R15-3P

Specify Number



R15-4a



R15-4b



R15-4c



R15-5



R15-5a

MUTCD 11th Edition Grade Crossing



R15-6



R15-6a



R15-7



R15-7a

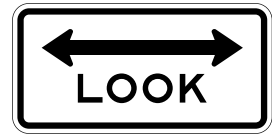

R15-8



W10-1



W10-1aP

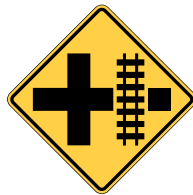

W10-2

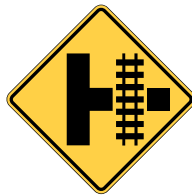

W10-3

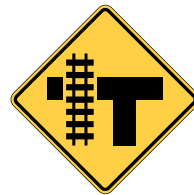

W10-4L

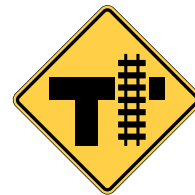

W10-4R



W10-5



W10-5P



W10-7
Activated
Blank-Out



W10-8

Specify Number



W10-9



W10-9P

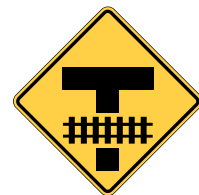

W10-11



W10-11a



W10-11b



W10-12L



W10-12R



W10-13P



W10-14P

Specify Number



W10-14aP



W10-15P



W10-16
Activated
Blank-Out



W10-21



W10-21aP

Note:

The W10-11 sign is a W10-3 sign modified for geometrics. Other signs can be oriented or revised as needed to better portray the geometrics of the roadways and the tracks.

Table 8B-1. Grade Crossing Sign and Plaque Minimum Sizes (Sheet 1 of 2)

Sign or Plaque	Sign Designation	Section	Conventional Road		Expressway	Minimum	Oversized
			Single Lane	Multi-Lane			
Stop	R1-1	8B.04, 8B.05	30 x 30	36 x 36	36 x 36	—	48 x 48
Yield	R1-2	8B.04, 8B.05	30 x 30 x 30	36 x 36 x 36	36 x 36 x 36	—	48 x 48 x 48
No Right Turn - Train (symbol)	R3-1a	8D.10	24 x 30	30 x 36	—	—	—
No Left Turn - Train (symbol)	R3-2a	8D.10	24 x 30	30 x 36	—	—	—
Do Not Stop on Tracks	R8-8	8B.07	24 x 30	24 x 30	36 x 48	—	36 x 48
Tracks Out of Service	R8-9	8B.08	24 x 24	24 x 24	36 x 36	—	36 x 36
Stop Here When Flashing	R8-10	8B.09	24 x 36	24 x 36	—	—	36 x 48
Stop Here When Flashing	R8-10a	8B.09	24 x 30	24 x 30	—	—	36 x 42
Stop Here on Red	R10-6	8B.10	24 x 36	24 x 36	—	—	36 x 48
Stop Here on Red	R10-6a	8B.10	24 x 30	24 x 30	—	—	36 x 42
Left (Right) Lane Signal	R10-10b	8D.11	30 x 36	30 x 36	—	24 x 30	—
Left (Right) Turn Lane Signal	R10-10c	8D.11	30 x 42	30 x 42	—	24 x 36	—
Grade Crossing (Crossbuck)	R15-1	8B.03	48 x 9	48 x 9	—	—	—
Number of Tracks (plaque)	R15-2P	8B.03	27 x 18	27 x 18	—	—	—
Exempt (plaque)	R15-3P	8B.11	24 x 12	24 x 12	—	—	—
Light Rail Only Right Lane	R15-4a	8B.12	24 x 30	24 x 30	—	—	—
Light Rail Only Left Lane	R15-4b	8B.12	24 x 30	24 x 30	—	—	—
Light Rail Only Center Lane	R15-4c	8B.12	24 x 30	24 x 30	—	—	—
Light Rail Do Not Pass (symbol)	R15-5	8B.13	24 x 30	24 x 30	—	—	—
Do Not Pass Stopped Train	R15-5a	8B.13	24 x 30	24 x 30	—	—	—
No Motor Vehicles On Tracks (symbol)	R15-6	8B.14	24 x 24	24 x 24	—	—	—
Do Not Drive On Tracks	R15-6a	8B.14	24 x 30	24 x 30	—	—	—
Light Rail Divided Highway (symbol)	R15-7	8B.15	24 x 24	24 x 24	—	—	—
Light Rail Divided Highway (T-Intersection) (symbol)	R15-7a	8B.15	24 x 24	24 x 24	—	—	—
Look	R15-8	8E.03	—	—	—	18 x 9	—
Grade Crossing Advance Warning	W10-1	8B.06	36 Dia.	36 Dia.	48 Dia.	—	48 Dia.
Exempt (plaque)	W10-1aP	8B.11	24 x 12	24 x 12	—	—	—
Grade Crossing and Intersection Advance Warning (symbol)	W10-2,3,4	8B.06	36 x 36	36 x 36	48 x 48	—	48 x 48
Low Ground Clearance (symbol)	W10-5	8B.16	36 x 36	36 x 36	48 x 48	—	48 x 48
Low Ground Clearance (plaque)	W10-5P	8B.16	30 x 24	30 x 24	—	—	—
Light Rail Activated Blank-Out (symbol)	W10-7	8B.17	24 x 24	24 x 24	—	—	—
Trains May Exceed 80 MPH	W10-8	8B.19	36 x 36	36 x 36	48 x 48	—	48 x 48
No Train Horn	W10-9	8B.20	36 x 36	36 x 36	48 x 48	—	48 x 48
No Train Horn (plaque)	W10-9P	8B.20	30 x 24	30 x 24	—	—	—
Storage Space (symbol)	W10-11	8B.21	36 x 36	36 x 36	48 x 48	—	48 x 48
Storage Space XX Feet between Tracks & Highway	W10-11a	8B.21	30 x 36	30 x 36	—	—	—
Storage Space XX Feet between Highway & Tracks Behind You	W10-11b	8B.21	30 x 36	30 x 36	—	—	—
Skewed Crossing (symbol)	W10-12	8B.22	36 x 36	36 x 36	48 x 48	—	48 x 48
No Gates or Lights (plaque)	W10-13P	8B.23	30 x 24	30 x 24	—	—	—
Next Crossing (plaque)	W10-14P	8B.24	30 x 24	30 x 24	—	—	—
Use Next Crossing (plaque)	W10-14aP	8B.24	30 x 24	30 x 24	—	—	—

Table 8B-1. Grade Crossing Sign and Plaque Minimum Sizes (Sheet 2 of 2)

Sign or Plaque	Sign Designation	Section	Conventional Road		Expressway	Minimum	Oversized
			Single Lane	Multi-Lane			
Rough Crossing (plaque)	W10-15P	8B.25	30 x 24	30 x 24	—	—	36 x 30
Another Train Coming Activated Blank-Out	W10-16	8B.18	30 x 30	30 x 30	—	—	—
Busway Crossing	W10-21	8B.06	36x36	36x36	48x48	—	48x48
Signal Ahead (plaque)	W10-21aP	8B.06	30x24	30x24	—	—	—
Emergency Notification	I13-1	8B.27	—	—	—	12 x 9	—
Push to Exit	I13-2	8E.06	—	—	—	18 x 9	—

- Notes: 1. Larger signs may be used when appropriate
 2. Dimensions in inches are shown as width x height
 3. Table 9A-1 shows the minimum sizes that may be used for grade crossing signs and plaques that face shared-use paths and pedestrian facilities

MUTCD 11th Edition Temporary Traffic Control Zone



W1-1L



W1-1R



W1-2L



W1-2R



W1-3L



W1-3R



W1-4L



W1-4R



W1-4bL



W1-4bR



W1-4cL



W1-4cR



W1-6



W1-8



W3-1



W3-2



W3-3



W3-4



W3-5

Specify Number



W3-5a

Specify Number

MUTCD 11th Edition Temporary Traffic Control Zone



W4-1L



W4-1R



W4-2L



W4-2R



W4-3L



W4-3R



W4-5L



W4-5R



W4-5aP



W4-6L



W4-6R



W5-1



W5-2



W5-3



W5-4



W6-1



W6-2



W6-3



W6-4



W7-1



W7-3aP

Specify Number



W8-1



W8-2



W8-3



W8-4



W8-5



W8-6

MUTCD 11th Edition Temporary Traffic Control Zone



W8-7



W8-8



W8-9



W8-11



W8-12



W8-14



W8-15



W8-16



W8-17



W8-18



W8-15aP



W8-17P



W8-23



W8-24



W8-25



W9-1



W9-1



W9-2a



W9-3L



W9-3R



W9-5a



W11-10



W12-1



W12-2

Specify Number



W13-1P



W13-4P



W14-3



W20-1*



W20-1b



W20-2

Specify Number

Specify #FEET, #MILES, AHEAD

* An optional STREET WORK word message sign

MUTCD 11th Edition Temporary Traffic Control Zone

** An optional STREET CLOSED word message sign

*** An optional FLAGGER (W20-7a) word message sign



W20-2a



W20-3**



W20-3a



W20-4

Specify #FEET, #MILES, AHEAD



W20-5L



W20-5R



W20-5aL



W20-5aR



W20-5b



W20-7***



W16-2P

Specify #FEET, #MILES, AHEAD

Specify Number



W20-8



W21-1



W21-1a



W21-2



W21-3



W21-4

Specify OIL or TAR



W21-5



W21-5aL



W21-5aR



W21-5bL



W21-5bR

Specify #FEET, #MILES, AHEAD



W21-6



W21-7



W21-8



W22-1

Specify #FEET, #MILES, AHEAD

MUTCD 11th Edition Temporary Traffic Control Zone



W22-3



W23-1



W23-2



W24-1L



W24-1R



W24-1aL



W24-1aR



W24-1bL



W24-1bR



W24-1cP



G20-1



G20-2



G20-4

Specify Number



E5-2



E5-2a



E5-3



M4-8P



M4-8a



M4-8bP



M4-9L



M4-9R



M4-9U



M4-9aL



M4-9aR



M4-9bL



M4-9bR



M4-9cL



M4-9cR



M4-10L



M4-10R

Table 6H-1. Temporary Traffic Control Zone Warning Sign and Plaque Sizes (Sheet 1 of 2)

Sign or Plaque	Sign Designation	Section	Conventional Road	Freeway or Expressway	Minimum
Turn and Curve Signs	W1-1,2,3,4	6H.01	36 x 36	48 x 48	30 x 30
Reverse Curve (2 or more lanes)	W1-4b,4c	6H.30	36 x 36	48 x 48	30 x 30
Large Arrow (1-direction)	W1-6	6H.01	48 x 24	60 x 30	—
Chevron Alignment	W1-8	6H.01	18 x 24	30 x 36	—
Stop Ahead	W3-1	6H.01	36 x 36	48 x 48	30 x 30
Yield Ahead	W3-2	6H.01	36 x 36	48 x 48	30 x 30
Signal Ahead	W3-3	6H.01	36 x 36	48 x 48	30 x 30
Be Prepared to Stop	W3-4	6H.01	36 x 36	48 x 48	30 x 30
Reduced Speed Limit Ahead	W3-5	6H.01	36 x 36	48 x 48	30 x 30
XX MPH Speed Zone Ahead	W3-5a	6H.01	36 x 36	48 x 48	30 x 30
Merging Traffic	W4-1,5	6H.01	36 x 36	48 x 48	36 x 36
Lane Ends	W4-2	6H.08	36 x 36	48 x 48	30 x 30
Added Lane	W4-3,6	6H.01	36 x 36	48 x 48	30 x 30
No Merge Area (plaque)	W4-5aP	6H.01	18 x 24	24 x 30	—
Road Narrows	W5-1	6H.01	36 x 36	48 x 48	30 x 30
Narrow Bridge	W5-2	6H.01	36 x 36	48 x 48	30 x 30
One Lane Bridge	W5-3	6H.01	36 x 36	48 x 48	30 x 30
Ramp Narrows	W5-4	6H.10	36 x 36	48 x 48	30 x 30
Divided Highway	W6-1	6H.01	36 x 36	48 x 48	30 x 30
Divided Highway Ends	W6-2	6H.01	36 x 36	48 x 48	30 x 30
Two-Way Traffic	W6-3	6H.16	36 x 36	48 x 48	30 x 30
Narrow Two-Way Traffic	W6-4	6H.17	12 x 18	12 x 18	—
Hill	W7-1	6H.01	36 x 36	48 x 48	30 x 30
Next XX Miles (plaque)	W7-3aP	6H.33	24 x 18	36 x 30	—
Bump	W8-1	6H.01	36 x 36	48 x 48	24 x 24
Dip	W8-2	6H.01	36 x 36	48 x 48	24 x 24
Pavement Ends	W8-3	6H.01	36 x 36	48 x 48	30 x 30
Soft Shoulder	W8-4	6H.26	36 x 36	48 x 48	30 x 30
Slippery When Wet	W8-5	6H.01	36 x 36	48 x 48	30 x 30
Truck Crossing	W8-6	6H.21	36 x 36	48 x 48	30 x 30
Loose Gravel	W8-7	6H.01	36 x 36	48 x 48	30 x 30
Rough Road	W8-8	6H.01	36 x 36	48 x 48	24 x 24
Low Shoulder	W8-9	6H.26	36 x 36	48 x 48	24 x 24
Uneven Lanes	W8-11	6H.27	36 x 36	48 x 48	30 x 30
No Center Line	W8-12	6H.29	36 x 36	48 x 48	30 x 30
Fallen Rocks	W8-14	6H.01	36 x 36	48 x 48	30 x 30
Grooved Pavement	W8-15	6H.01	36 x 36	48 x 48	30 x 30
Motorcycle (plaque)	W8-15aP	6H.34	24 x 18	30 x 24	—
Metal Bridge Deck	W8-16	6H.34	36 x 36	48 x 48	30 x 30
Shoulder Drop Off (symbol)	W8-17	6H.26	36 x 36	48 x 48	30 x 30
Shoulder Drop-Off (plaque)	W8-17P	6H.26	24 x 18	30 x 24	—
Road May Flood	W8-18	6H.01	36 x 36	48 x 48	24 x 24
No Shoulder	W8-23	6H.01	36 x 36	48 x 48	30 x 30
Steel Plate Ahead	W8-24	6H.28	36 x 36	48 x 48	30 x 30
Shoulder Ends	W8-25	6H.01	36 x 36	48 x 48	30 x 30
Lane Ends	W9-1,2	6H.01	36 x 36	48 x 48	30 x 30
Merge Here Take Turns	W9-2a	6N.19	36 x 48	36 x 48	—
Interior Lane Shift Ahead	W9-3	6H.07	36 x 36	48 x 48	30 x 30

Table 6H-1. Temporary Traffic Control Zone Warning Sign and Plaque Sizes (Sheet 2 of 2)

Sign or Plaque	Sign Designation	Section	Conventional Road	Freeway or Expressway	Minimum
Bicycles Merging	W9-5a	6P.01	30 x 30	—	18 x 18
Grade Crossing Advance Warning	W10-1	6H.01	36 dia.	48 Dia.	—
Truck	W11-10	6H.21	36 x 36	48 x 48	24 x 24
Double Arrow	W12-1	6H.01	30 x 30	36 x 36	—
Low Clearance	W12-2	6H.01	36 x 36	48 x 48	30 x 30
Advisory Speed (plaque)	W13-1P	6H.32	18 x 18	24 x 24	18 x 18
On Ramp (plaque)	W13-4P	6H.09	36 x 36	36 x 36	—
No Passing Zone (pennant)	W14-3	6H.01	48 x 48 x 36	64 x 64 x 48	40 x 40 x 30
XX Feet (2-line plaque)	W16-2P	6H.01	24 x 18	30 x 24	—
Road Work (with distance)	W20-1	6H.03	36 x 36	48 x 48	30 x 30
Path Work (with distance)	W20-1b	6P.01	36 x 36	—	30 x 30
Detour (with distance)	W20-2	6H.04	36 x 36	48 x 48	30 x 30
Bike Detour (with distance)	W20-2a	6P.01	36 x 36	—	30 x 30
Bike Diversion (with distance)	W20-2b	6P.01	36 x 36	—	30 x 30
Road Closed (with distance)	W20-3	6H.05	36 x 36	48 x 48	30 x 30
Path Closed (with distance)	W20-3a	6P.01	36 x 36	—	30 x 30
One Lane Road (with distance)	W20-4	6H.06	36 x 36	48 x 48	30 x 30
Lane(s) Closed (with distance)	W20-5,5a	6H.07	36 x 36	48 x 48	30 x 30
Bike Lane Closed (with distance)	W20-5b	6P.01	36 x 36	—	30 x 30
Flagger (symbol)	W20-7	6H.15	36 x 36	48 x 48	30 x 30
Flagger	W20-7a	6H.15	36 x 36	48 x 48	30 x 30
Slow (on Stop/Slow Paddle)	W20-8	6D.02	18 x 18	—	—
Workers	W21-1,1a	6H.18	36 x 36	48 x 48	30 x 30
Fresh Oil	W21-2	6H.19	36 x 36	48 x 48	30 x 30
Road Machinery Ahead	W21-3	6H.20	36 x 36	48 x 48	30 x 30
Slow Moving Vehicle	W21-4	6N.05	36 x 18	—	—
Shoulder Work	W21-5	6H.22	36 x 36	48 x 48	30 x 30
Shoulder Closed	W21-5a	6H.22	36 x 36	48 x 48	30 x 30
Shoulder Closed (with distance)	W21-5b	6H.22	36 x 36	48 x 48	30 x 30
Survey Crew	W21-6	6H.23	36 x 36	48 x 48	30 x 30
Utility Work (with distance)	W21-7	6H.24	36 x 36	48 x 48	30 x 30
Mowing Ahead	W21-8	6N.05	36 x 36	48 x 48	30 x 30
Blasting Zone Ahead	W22-1	6H.25	36 x 36	48 x 48	30 x 30
End Blasting Zone	W22-3	6H.25	42 x 36	42 x 36	36 x 30
Slow Traffic Ahead	W23-1	6H.11	48 x 24	48 x 24	—
New Traffic Pattern Ahead	W23-2	6H.14	36 x 36	48 x 48	30 x 30
Double Reverse Curve (1 lane)	W24-1	6H.31	36 x 36	48 x 48	30 x 30
Double Reverse Curve (2 lanes)	W24-1a	6H.31	36 x 36	48 x 48	30 x 30
Double Reverse Curve (3 lanes)	W24-1b	6H.31	36 x 36	48 x 48	30 x 30
All Lanes (plaque)	W24-1cP	6H.31	24 x 18	30 x 24	—
Road Work Next XX Miles	G20-1	6H.35	36 x 18	48 x 24	—
End Road Work	G20-2	6H.36	36 x 18	48 x 24	—
Pilot Car Follow Me	G20-4	6H.37	36 x 18	—	—

* See Table 2C-1 for minimum size required for signs facing traffic on multi-lane conventional roads

Notes: See Chapter 2C for information on the application of these signs.

1. Larger signs may be used wherever necessary for greater legibility or emphasis
2. Dimensions are shown in inches and are shown as width x height

Table 6I-1. Temporary Traffic Control Zone Guide Sign and Plaque Sizes

Sign or Plaque	Sign Designation	Section	Conventional Road	Freeway or Expressway	Minimum
Exit Open	E5-2	6H.12	48 x 36	48 x 36	—
Exit Closed	E5-2a	6H.12	48 x 36	48 x 36	—
Exit Only	E5-3	6H.13	48 x 36	48 x 36	—
Detour	M4-8P	6I.02	24 x 12	30 x 15	—
End Detour	M4-8a	6I.02	24 x 18	24 x 18	—
End (plaque)	M4-8bP	6I.02	24 x 12	24 x 12	—
Detour	M4-9	6I.02	30 x 24	48 x 36	—
Bike/Pedestrian Detour	M4-9a	6I.02	30 x 24	—	—
Pedestrian Detour	M4-9b	6I.02	30 x 24	—	—
Bike Detour (with arrow)	M4-9c	6I.02	30 x 24	—	—
Detour	M4-10	6I.02	48 x 18	—	—

Notes:

1. Larger signs may be used wherever necessary for greater legibility or emphasis
2. Dimensions are shown in inches and are shown as width x height

MUTCD 11th Edition

Temporary Traffic Control Zone - Regulatory Signs & Plaques

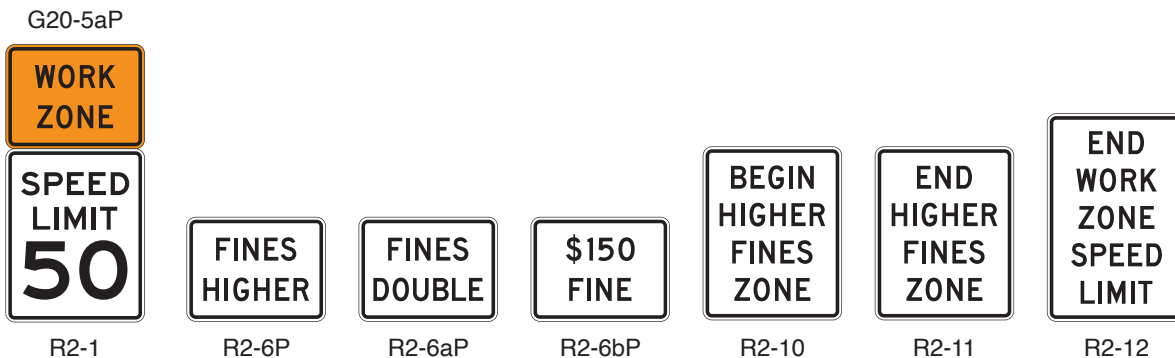

Specify Number

Specify Number

MUTCD 11th Edition

Temporary Traffic Control Zone - Regulatory Signs & Plaques



R3-1



R3-2



R3-3



R3-4



R3-5L



R3-5R

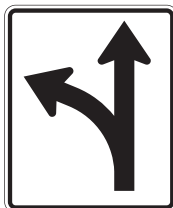

R3-6L



R3-6R



R3-7L



R3-7R



R3-8



R3-18



R3-27

Specify Arrows | ONLY
Layouts Required



R4-1



R4-2



R4-7



R4-7c



R4-9



R4-9a



R5-1



R5-1a



R6-1L



R6-1R



R6-2L



R6-2R



R8-3

MUTCD 11th Edition

Temporary Traffic Control Zone - Regulatory Signs & Plaques



R9-8



R9-9



R9-10



R9-11



R9-11a



R9-12

Specify Arrow

Specify Arrow



R9-20



R10-6L



R10-6R



R22-2



R11-2



R11-2a



R11-2b



R11-2c

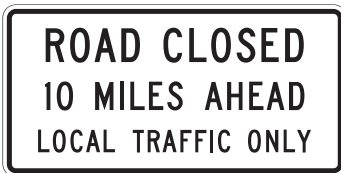

R11-3

Specify Number



R11-3a

Specify Number

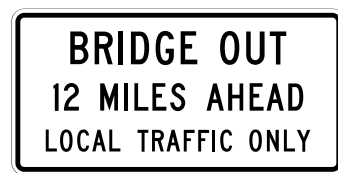

R11-3b

Specify Number



R11-4 Specify Message



R12-1

Specify Number



R12-2

Specify Number

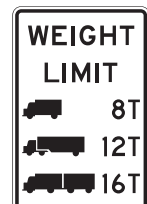

R12-5

Specify Numbers

Table 6G-1. Temporary Traffic Control Zone Regulatory Sign and Plaque Sizes

Sign or Plaque	Sign Designation	Section	Conventional Road	Freeway or Expressway	Minimum
Stop	R1-1	6G.02	30 x 30*	—	—
Stop (on Stop/Slow Paddle)	R1-1	6D.02	18 x 18	—	—
Yield	R1-2	6G.02	36 x 36 x 36*	—	30 x 30 x 30
To Oncoming Traffic (plaque)	R1-2aP	6G.02	36 x 30	48 x 36	24 x 18
Wait on Stop	R1-7	6L.03	24 x 30	24 x 30	—
Wait on Stop - Go on Slow	R1-7a	6G.03	30 x 36	30 x 36	—
Go on Slow	R1-8	6L.03	24 x 30	24 x 30	—
Speed Limit	R2-1	6G.08	24 x 30*	36 x 48	—
Fines Higher (plaque)	R2-6P	6G.08	24 x 18	36 x 24	—
Fines Double (plaque)	R2-6aP	6G.08	24 x 18	36 x 24	—
\$XX Fine (plaque)	R2-6bP	6G.08	24 x 18	36 x 24	—
Begin Higher Fines Zone	R2-10	6G.08	24 x 30	36 x 48	—
End Higher Fines Zone	R2-11	6G.08	24 x 30	36 x 48	—
End Work Zone Speed Limit	R2-12	6G.08	24 x 36	36 x 54	—
Movement Prohibition	R3-1,2,3,4	6G.02	24 x 24*	36 x 36	—
Mandatory Movement Lane Control - Turn Only	R3-5	6G.02	30 x 36	—	—
Optional Movement Lane Control - Thru and Turn	R3-6	6G.02	30 x 36	—	—
Right (Left) Lane Must Turn Right (Left)	R3-7	6G.02	30 x 30*	—	—
Advance Intersection Lane Control (2 lanes)	R3-8	6G.02	30 x 30	—	—
Movement Prohibition - No U or Left Turn	R3-18	6G.02	24 x 24*	36 x 36	—
Movement Prohibition - No Straight Through	R3-27	6G.02	24 x 24*	36 x 36	—
Do Not Pass	R4-1	6G.02	24 x 30	36 x 48	—
Pass With Care	R4-2	6G.02	24 x 30	36 x 48	—
Keep Right	R4-7	6G.02	24 x 30	36 x 48	—
Narrow Keep Right	R4-7c	6G.02	18 x 30	—	—
Stay in Lane	R4-9	6G.07	24 x 30	36 x 48	—
Stay In Lane To Merge Point	R4-9a	6G.07	36 x 48	36 x 48	—
Do Not Enter	R5-1	6G.02	30 x 30*	36 x 36	—
Wrong Way	R5-1a	6G.02	36 x 24*	42 x 30	—
One Way	R6-1	6G.02	36 x 12*	48 x 18	—
One Way	R6-2	6G.02	24 x 30*	36 x 48	—
No Parking (symbol)	R8-3	6G.02	24 x 24*	36 x 36	—
Pedestrian Crosswalk	R9-8	6G.09	36 x 18	—	—
Sidewalk Closed	R9-9	6G.10	24 x 12	—	—
Sidewalk Closed, Use Other Side	R9-10	6G.10	24 x 12	—	—
Sidewalk Closed Ahead, Cross Here	R9-11	6G.10	24 x 18	—	—
Sidewalk Closed, Cross Here	R9-11a	6G.10	24 x 12	—	—
Bike Lane Closed	R9-12	6P.01	24 x 12	—	—
Stop Here on Red	R10-6	6L.04	24 x 36	—	—
Road Closed	R11-2, 2a, 2b, 2c	6G.04	48 x 30	—	—
Road Closed - Local Traffic Only	R11-3, 3a, 3b, 4	6G.05	60 x 30	—	—
Weight Limit	R12-1, 2	6G.06	24 x 30	36 x 48	—
Weight Limit	R12-5	6G.06	24 x 36	36 x 48	—
Turn Off 2-Way Radio and Cell Phone	R22-2	6G.11	42 x 36	42 x 36	—
Work Zone (plaque)	G20-5aP	6G.08	24 x 18	30 x 24	—

* See Table 2B-1 for minimum size required for signs facing traffic on multi-lane conventional roads

Notes: See Chapter 2B for information on the application of these signs.

1. Larger signs may be used wherever necessary for greater legibility or emphasis
2. Dimensions are shown in inches and are shown as width x height

BARRICADES

Part number	Part Description	
FBARRPOLY1D72X8L	BARR POLY 1 SIDE DGC 72 X 8 LT	
FBARRPOLY1P72X8L	BARR POLY 1 SIDE HIP 72 X 8 LT	
FBARRPOLY1D72X8R	BARR POLY 1 SIDE DGC 72 X 8 RT	
FBARRPOLY1P72X8R	BARR POLY 1 SIDE HIP 72 X 8 RT	
FBARRPOLY1D96X8L	BARR POLY 1 SIDE DGC 96 X 8 LT	
FBARRPOLY1P96X8L	BARR POLY 1 SIDE HIP 96 X 8 LT	
FBARRPOLY1D96X8R	BARR POLY 1 SIDE DGC 96 X 8 RT	
FBARRPOLY1P96X8R	BARR POLY 1 SIDE HIP 96 X 8 RT	
FBARRPOLY2D72X8	BARR POLY 2-SIDED DGC 72 X 8	
FBARRPOLY2P72X8	BARR POLY 2-SIDED HIP 72 X 8	
FBARRPOLY2D96X8	BARR POLY 2-SIDED DGC 96 X 8	
FBARRPOLY2P96X8	BARR POLY 2-SIDED HIP 96 X 8	
FBARRSTD2DPLY24X8	BARR POLY TYPE2 DGC 24X8	
FBARRSTD2DPLY36X8	BARR POLY TYPE2 DGC 36 X 8	
FBARRSTD2PPLY24X8	BARR POLY TYPE2 HIP 24X8	
FBARRSTD2PPLY36X8	BARR POLY TYPE2 HIP 36 X 8	
FBARRSTD3EZKADE	TYPE 3 EZ KADE BARRICADE	

* Warning lights (optional)

** Rail stripe widths shall be 6 inches, except that 4-inch wide stripes may be used if rail lengths are less than 36 inches. The sides of barricades facing traffic shall have retroreflective rail faces.

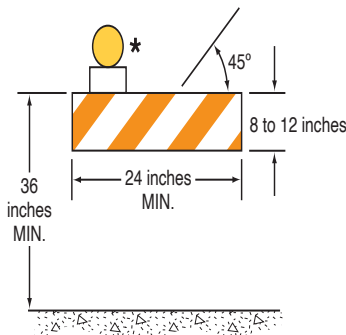

TYPE 1 BARRICADE **

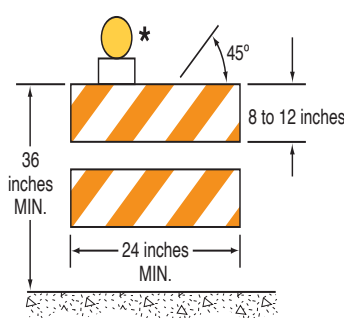

TYPE 2 BARRICADE **

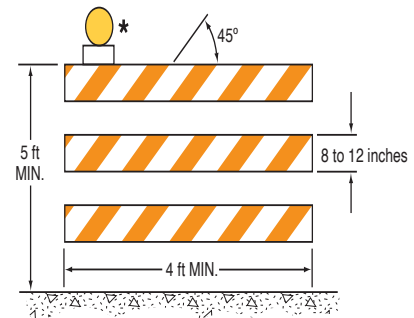

TYPE 3 BARRICADE **

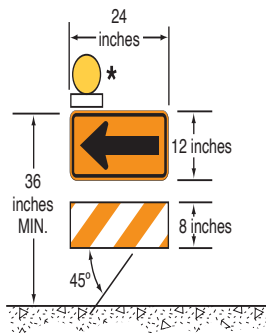

DIRECTION INDICATOR BARRICADE **

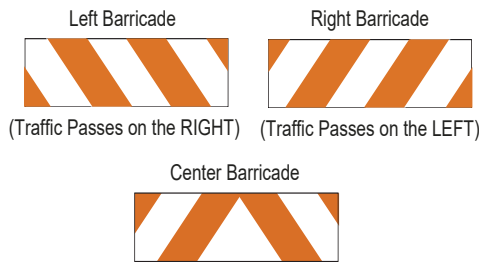

(Traffic Passes on both Left & Right)



EZKADE

Barricades alert drivers to hazards created by construction and maintenance operations and guide them safely by The Federal Highway Administration manual on Uniform Traffic Control Devices states that "the entire area of white and orange stripes shall be reflectorized," and must be visible under "normal atmospheric conditions from a minimum distance of 1,000 feet when illuminated by low beams of standard automobile headlights."

CONES

Part number	Part Description	
RCONE28	CONE TRAFFIC 28"	
FCONEW-STRIPES	CONE TRAFFIC 28" w/ STRIPES	

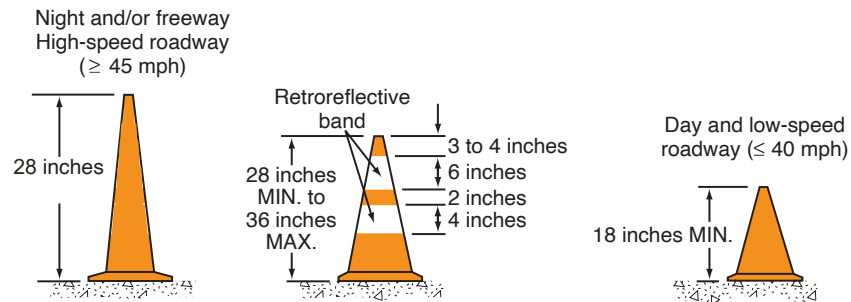

HINGED SIGNS

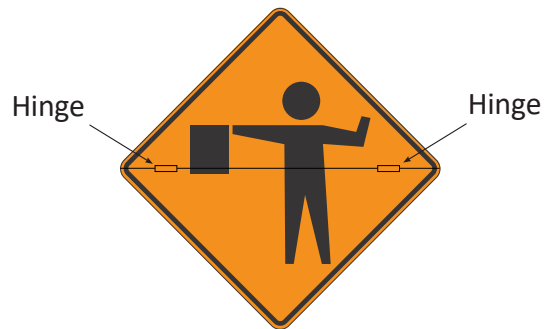

- The hinges are approximately 2-1/4" long
- Signs under 35" in length use 2 hinges placed approximately 6" inches from edge of sign.
- Signs 36" to 48" in length use 3 hinges
(2 placed approximately 3" from edge of sign and 1 centered)
- Signs 48" and above use 4 or more hinges

MUTCD 11th Edition Bicycle Facility



R1-1



R1-2



R3-5hP



R3-7bP



R3-17



R3-17aP



R3-17bP



R4-1



R4-2



R4-3



R4-4

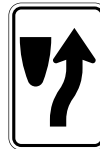

R4-7

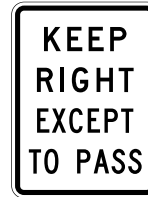

R4-16



R4-19

Specify Number



R5-1b



R9-3cP



R5-3



R5-6



R5-10dP



R7-9



R7-9a



R7-10

Specify Arrow



R9-3



R9-5



R9-6



R9-7L



R9-7R



R9-13



R9-14



R9-15



R9-16



R9-20



R9-21



R9-22

MUTCD 11th Edition Bicycle Facility



R9-23



R9-23a



R9-23b



R9-23c



R9-24



R9-24a



R9-25



R9-25a



R9-25b

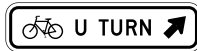

R9-26

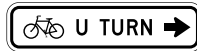

R9-26a



R9-26b



R9-27



R9-27a



R9-27b

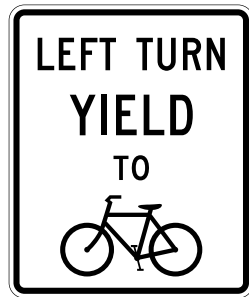

R10-12b



R10-4



R10-22



R10-24



R10-25



R10-26

Specify Arrow

Specify Arrow



R10-40



R10-40a



R10-41

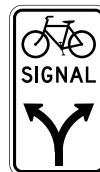

R10-41a



R10-41b



R10-41c

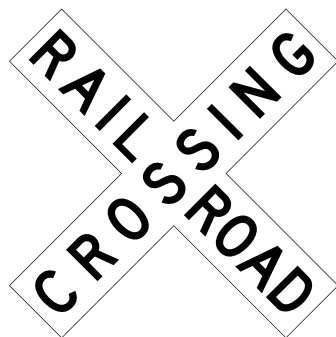

R15-1



R15-2P

Specify Number

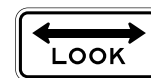

R15-8

MUTCD 11th Edition Bicycle Facility



W1-1L



W1-1R



W1-2L



W1-2R

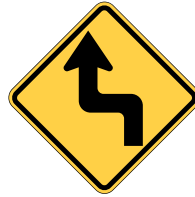

W1-3L



W1-3R



W1-4L



W1-4R



W1-5L



W1-5R



W1-6



W1-7



W2-1



W2-2



W2-3L



W2-3R



W2-4



W2-5



W3-1



W3-2



W3-3



W5-2



W5-4a



W7-5

MUTCD 11th Edition Bicycle Facility

* A fluorescent yellow-green background color may be used for this sign or plaque. The background color of the plaque should match the color of the warning sign that it supplements.



W8-1



W8-2



W8-3



W8-10



W9-5



W8-10P



W9-5a



W10-1



W10-9P



W10-12L



W10-12R



W11-1*



W11-2*



W11-15*



W12-2

Specify Number

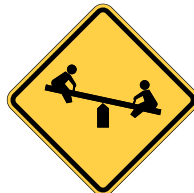

W15-1*



W16-1P*



W16-1aP*



W16-2P*

Specify Number



W16-2aP*

Specify Number



W11-15P*



W16-7PL*



W16-7PR*



W16-9P*



W16-20P



W16-21P



OM3-L



OM3-C



OM3-R

MUTCD 11th Edition Bicycle Facility



D1-1



D1-1a



D1-1b

Specify Arrow Direction, Destination, Miles when appropriate



D1-1c



D1-2



D1-2a



D1-2b

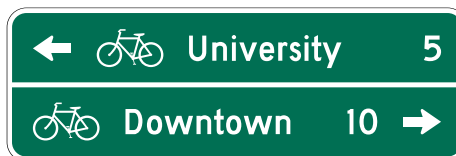

D1-2c



D1-3

Specify Arrow Direction, Destination, Miles when appropriate



D1-3a



D1-3b



D1-3c



D2-1



D2-1a



D2-2



D2-2a

Specify Arrow Direction, Destination, Miles



D2-3



D2-3a



D3-1

Specify Destination

MUTCD 11th Edition Bicycle Facility



D4-3

Specify Arrow



D4-4

Specify Arrow



D4-4a

Specify Arrow



D10-1



D10-1a



D10-2



D10-2a



D10-3



D10-3a

Specify Mile Marker Number



D11-1



D11-1bP



D11-1c

Specify Destination



D11-10a



D11-10b

Specify Arrow Direction, Destination



D11-10c



D11-10d



D11-10e

Specify Arrow Direction, Destination and Miles



D11-10f

MUTCD 11th Edition Bicycle Facility



D11-11



D11-12



D11-13

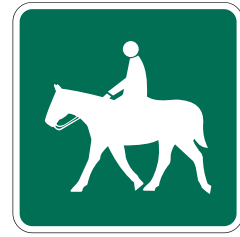

D11-14



D11-20

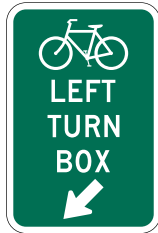

D11-20a



M1-8

Specify Number



M1-8a

Specify Number



M1-8b

Specify Destination



M1-8c

Specify Destination



M1-9

Specify Number



M2-1P



M3-1P



M3-2P



M3-3P



M3-4P



M4-1P



M4-1aP



M4-2P



M4-3P



M4-5P



M4-6P



M4-7P



M4-7aP



M4-8P



M4-14P



M5-1PL



M5-1PR



M5-2PL



M5-2PR



M6-1P



M6-2PL



M6-2PR



M6-3P



M6-4P



M6-5PL



M6-5PR



M6-6PL



M6-6PR



M6-7PL



M6-7PR

Table 9A-1. Bicycle Facility Sign and Plaque Minimum Sizes (Sheet 1 of 3)

Sign or Plaque	Sign Designation	Section	Off Roadway ^{1,5}	Roadway ^{2,5}
Stop	R1-1	9B.01	18 x 18	—
Yield	R1-2	9B.01	18 x 18 x 18	—
Bike Lane (plaque)	R3-5hP	9B.04	—	30 x 12
Except Bicycles (plaque)	R3-7bP	9B.02	—	24 x 12
Advance Intersection Lane Control with Bike Lane	R3-8x Series	9B.03	—	Varies x 36
Bike Lane	R3-17	9B.04	—	24 x 18
Ahead, Ends (plaques)	R3-17aP, R3-17bP	9B.04	—	24 x 9
Movement Restriction	R4-1,2,3,7,16	9B.24	12 x 18	—
Begin Right Turn Lane Yield to Bikes	R4-4	9B.05	—	36 x 30
Bicycle Passing Clearance	R4-19	9B.15	—	30 x 30
Bicycle Wrong Way	R5-1b	9B.06	12 x 18	12 x 18
No Motor Vehicles	R5-3	9B.07	24 x 24	24 x 24
No Bicycles	R5-6	9B.08	18 x 18	—
On Freeway (plaque)	R5-10dP	9B.17	—	24 x 6
No Parking Bike Lane	R7-9,9a	9B.09	—	12 x 18
Back-In Parking	R7-10	9B.10	—	12 x 18
No Pedestrian Crossing	R9-3	9B.08	18 x 18	—
Ride With Traffic (plaque)	R9-3cP	9B.06	12 x 12	12 x 12
Bicycles Use Pedestrian Signal	R9-5	9B.11	12 x 18	12 x 18
Bicycles Yield to Pedestrians	R9-6	9B.12	12 x 18	12 x 18
Shared-Use Path Restriction	R9-7	9B.13	12 x 18*	—
No Skaters	R9-13	9B.08	18 x 18	18 x 18
No Equestrians	R9-14	9B.08	18 x 18	18 x 18
No Snowmobiles	R9-15	9B.08	18 x 18	18 x 18
No All-Terrain Vehicles	R9-16	9B.08	18 x 18	18 x 18
Bicycles Allowed Use of Full Lane	R9-20	9B.14	—	30 x 30
Bicycles Use Shoulder Only	R9-21	9B.16	—	24 x 30
Bicycles Must Exit	R9-22	9B.17	—	24 x 30
Bicycle All Turns from Bike Lane	R9-23	9B.18	—	12 x 18
Bicycle Left Turn from Bike Lane	R9-23a	9B.18	—	12 x 18
Bicycle Left Turn Must Use Turn Box	R9-23b, R9-23c	9B.18	—	12 x 18
Bicycle All Turns	R9-24,24a	9B.19	—	24 x 6
Bicycle U and Left Turns	R9-25,25a,25b	9B.19	—	24 x 9
Bicycle U Turn	R9-26,26a,26b	9B.19	—	24 x 6
Bicycle Left Turn	R9-27,27a,27b	9B.19	—	24 x 6
Push Button for Green	R10-4	9B.20	9 x 12	9 x 12
Left Turn Yield to Bicycle	R10-12b	9B.21	—	30 x 36
Bicycle Detector	R10-22	9B.20	12 x 18	12 x 18
Bike Push Button for Green Light	R10-24	9B.20	9 x 15	9 x 15
Push Button for Warning Lights - Wait for Gap	R10-25	9B.20	9 x 12	9 x 12
Bike Push Button for Green Light (arrow)	R10-26	9B.20	9 x 15	9 x 15
Bicycle Signal	R10-40, R10-40a, R10-41, R10-41a, R10-41b, R10-41c	9B.22	12 x 21	12 x 21
Grade Crossing (Crossbuck)	R15-1	9B.23	24 x 4.5	48 x 9
Number of Tracks (plaque)	R15-2P	9B.23	13.5 x 9	27 x 18
Look	R15-8	9B.23	18 x 9	36 x 18
Horizontal Alignment	W1-1,2,3,4,5	9C.01	18 x 18	—
Large Arrow	W1-6,7	9C.01	24 x 12	—
Intersection Warning	W2-1,2,3,4,5	9C.02	18 x 18	—

Table 9A-1. Bicycle Facility Sign and Plaque Minimum Sizes (Sheet 2 of 3)

Sign or Plaque	Sign Designation	Section	Off Roadway ^{1,5}	Roadway ^{2,5}
Stop Ahead, Yield Ahead, Signal Ahead	W3-1,2,3	9C.08	18 x 18	—
Narrow Bridge	W5-2	9C.08	18 x 18	—
Path Narrows	W5-4a	9C.08	18 x 18	—
Hill	W7-5	9C.08	18 x 18	30 x 30
Bump, Dip	W8-1,2	9C.03	18 x 18	—
Pavement Ends	W8-3	9C.03	18 x 18	—
Bicycle Surface Condition	W8-10	9C.03	18 x 18	30 x 30
Slippery When Wet (plaque)	W8-10P	9C.03	12 x 9	12 x 9
Bicycle Lane Ends	W9-5	9C.07	—	30 x 30
Bicycles Merging	W9-5a	9C.07	18 x 18	30 x 30
Grade Crossing Advance Warning	W10-1	9C.08	24 Dia.	36 Dia.
No Train Horn (plaque)	W10-9P	9C.08	18 x 12	30 x 24
Skewed Crossing	W10-12	9C.08	18 x 18	36 x 36
Bicycle	W11-1	9C.04, 9C.08	18 x 18	—
Pedestrian	W11-2	9C.08	18 x 18	—
Trail Crossing	W11-15	9C.04	18 x 18	—
Trail Crossing (plaque)	W11-15P	9C.04	18 x 12	—
Low Clearance	W12-2	9C.08	18 x 18	—
Playground	W15-1	9C.08	18 x 18	—
In Road (plaque)	W16-1P	9C.08	—	18 x 12
In Street (plaque)	W16-1aP	9C.08	—	18 x 12
XX Feet (2-line plaque)	W16-2P	9C.04	18 x 12	—
XX Ft (1-line plaque)	W16-2aP	9C.04	12 x 9	—
Downward Diagonal Arrow (plaque)	W16-7P	9C.04	12 x 9	—
Ahead (plaque)	W16-9P	9C.04	—	24 x 12
Except Bicycles (plaque)	W16-20P	9C.05	—	24 x 12
2-Way Bicycle Cross Traffic (plaque)	W16-21P	9C.06	—	24 x 12
Object Marker Type 3	OM3-L,C,R	9C.09	6 x 18	12 x 36
Destination (1 line)	D1-1, D1-1a	9D.01	Varies x 6	—
Bicycle Destination (1 line)	D1-1b, D1-1c	9D.01	Varies x 6	Varies x 6
Destination (2 lines)	D1-2, D1-2a	9D.01	Varies x 12	—
Bicycle Destination (2 lines)	D1-2b, D1-2c	9D.01	Varies x 12	Varies x 12
Destination (3 lines)	D1-3, D1-3a	9D.01	Varies x 18	—
Bicycle Destination (3 lines)	D1-3b, D1-3c	9D.01	Varies x 18	Varies x 18
Distance (1 line)	D2-1	9D.01	Varies x 6	—
Bike Route Destination and Distance (1 Line)	D2-1a	9D.01	Varies x 12	Varies x 12
Distance (2 line)	D2-2	9D.01	Varies x 9	—
Bike Route Destination and Distance (2 Lines)	D2-2a	9D.01	Varies x 15	Varies x 15
Distance (3 line)	D2-3	9D.01	Varies x 12	—
Bike Route Destination and Distance (3 Lines)	D2-3a	9D.01	Varies x 18	Varies x 18
Street Name (1 line)	D3-1	9D.01	Varies x 6	Varies x 6
Street Name (2 lines)	D3-1	9D.01	Varies x 12	Varies x 12
Bicycle Parking Area Directional	D4-3	9D.09	18 x 12	18 x 12
Bicycle-Sharing Station Directional	D4-4	9D.09	12 x 18	12 x 18
Bicycle Lockers Directional	D4-4a	9D.09	12 x 18	12 x 18
Reference Location (1-digit)	D10-1	9D.10	6 x 9	—
Intermediate Reference Location (2-digits)	D10-1a	9D.10	6 x 15	—
Reference Location (2-digits)	D10-2	9D.10	6 x 15	—
Intermediate Reference Location (3-digits)	D10-2a	9D.10	6 x 21	—

Table 9A-1. Bicycle Facility Sign and Plaque Minimum Sizes (Sheet 3 of 3)

Sign or Plaque	Sign Designation	Section	Off Roadway ^{1,5}	Roadway ^{2,5}
Reference Location (3-digits)	D10-3	9D.10	6 x 21	—
Intermediate Reference Location (4-digits)	D10-3a	9D.10	6 x 24	—
Bike Route	D11-1	9D.02	24 x 18	24 x 18
Bike Route (plaque)	D11-1bP	9D.03	18 x 6	18 x 6
Bike Route with Destination	D11-1c	9D.02	24 x 18	24 x 18
Shared-Use Path Destination (1 line)	D11-10a	9D.12	Varies x 6*	—
Shared-Use Path Destination (2 lines)	D11-10b	9D.12	Varies x 12*	—
Shared-Use Path Destination (3 lines)	D11-10c	9D.12	Varies x 18*	—
Shared-Use Path Destination and Distance (1 line)	D11-10d	9D.12	Varies x 6*	—
Shared-Use Path Destination and Distance (2 lines)	D11-10e	9D.12	Varies x 12*	—
Shared-Use Path Destination and Distance (3 lines)	D11-10f	9D.12	Varies x 18*	—
Bicycles Directional	D11-11	9D.11	18 x 18	—
Pedestrians Directional	D11-12	9D.11	18 x 18	—
Skaters Directional	D11-13	9D.11	18 x 18	—
Equestrians Directional	D11-14	9D.11	18 x 18	—
Bicycle Turn Box Guide Signs	D11-20, D11-20a	9D.13	—	12 x 18
State or Local Bicycle Route	M1-8, M1-8a	9D.05	12 x 18	18 x 24
Non-Numbered Bicycle Route	M1-8b, M1-8c	9D.06	12 x 12	18 x 18
U.S. Bicycle Route	M1-9	9D.07	12 x 18	18 x 24
Bicycle Route Auxiliary Signs (plaque)	M2-1P, M3-1P, 2P, 3P, 4P, M4-1P, 1aP, 2P, 3P, 5P, 6P, 7P, 7aP, 8P, 14P	9D.08	12 x 6	12 x 6
Bicycle Route Arrow Signs (plaque)	M5-1P, 2P, M6-1P, 2P, 3P, 4P, 5P, 6P, 7P	9D.08	12 x 9	12 x 9

* For use on shared-use paths only.

Notes: 1. Includes shared-use paths and bicycle-only facilities outside of the roadway.

2. If the sign or plaque applies to motorists and bicyclists, then the size shall be as shown for conventional roads in Tables 2B-1, 2C-1, 2D-1, or 8B-1.
3. Larger signs may be used when appropriate.
4. Dimensions are shown in inches and are shown as width x height.
5. Separated bicycle lanes (see definition in Section 1C.02) can be located within the roadway or outside the roadway, and the minimum sign sizes for these facilities are shown in the off roadway and roadway columns respectively.

MUTCD 11th Edition Recreational & Cultural Interest Area Symbols



RS-002*
Smoking



RS-005*
Tunnel



RS-006
Lookout Tower



RS-011
Deer Viewing Area



RS-031*
Bus Stop



RS-036
Viewing Area



RS-042*
Campfires



RS-090*
Fire Extinguisher



RS-115
Sea Plane



RS-140*
Pick-Up Trucks



RS-141
Nature Study Area



RS-200*
Recycling



RS-021*
Men's Restroom



RS-022*
Restrooms



RS-023*
Women's Restroom



RS-034
Parking



RS-037
Sleeping Shelter



RS-040*
Trailer Site



RS-104*
Recreational Vehicle Site



RS-024*
First Aid



RS-026*
Post Office



RS-035*
Showers



RS-039
Picnic Shelter



RS-044
Picnic Site



RS-085*
Laundromat



RS-091*
Trash Dumpster

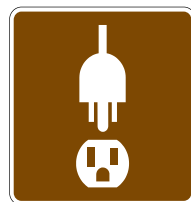

RS-150*
Electrical Hook-Up

MUTCD 11th Edition Recreational & Cultural Interest Area Symbols



RS-064
Horse Trail



RS-068
Hiking Trail

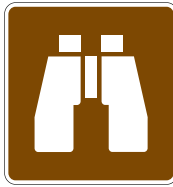

RS-076
Wildlife Viewing



RS-082
Climbing



RS-084*
Spelunking/Caves



RS-095
All-Terrain Trail



RS-096
Baseball



RS-098*
Skateboarding



RS-116
Archery



RS-125*
In-Line Skating



RS-128
Golfing



RS-129
Tennis



RS-053*
Marina



RS-054
Boat Ramp



RS-055
Motorboating



RS-058
Waterskiing



RS-060
Scuba Diving



RS-061
Swimming

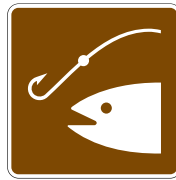

RS-063
Fishing Area



RS-079
Canoeing



RS-117*
Hand Launch/
Small Boat Launch



RS-121
Jet Ski/Personal
Watercraft



RS-145
Beach



RS-046
Cross Country Skiing



RS-049
Sledding



RS-077
Winter Recreational Area



RS-078
Snowshoeing



RS-105
Chair Lift/Ski Lift



RS-144
Snow Tubing

Category Chart for Recreational and Cultural Interest Area Symbols

General	
Bear Viewing Area	RS-012
Bus Stop *	RS-031
Campfires *	RS-042
Deer Viewing Area	RS-011
Fire Extinguisher *	RS-090
Lighthouse	RS-007
Lookout Tower	RS-006
Nature Study Area	RS-141
Pick-Up Trucks *	RS-140
Recycling *	RS-200
Sea Plane	RS-115
Tunnel *	RS-005
Viewing Area	RS-036

Land Recreation	
All-Terrain Trail	RS-095
Archery	RS-116
Baseball	RS-096
Climbing	RS-082
Golfing	RS-128
Hiking Trail	RS-068
Horse Trail	RS-064
In-Line Skating *	RS-125
Skateboarding *	RS-098
Spelunking/Caves *	RS-084
Technical Rock Climbing *	RS-081
Tennis	RS-129
Wildlife Viewing	RS-076

Accommodations	
Men's Restroom *	RS-021
Parking	RS-034
Recreational Vehicle Site *	RS-104
Restrooms *	RS-022
Sleeping Shelter	RS-037
Smoking *	RS-002
Trailer Site *	RS-040
Women's Restroom *	RS-023

Water Recreation	
Beach	RS-145
Boat Ramp	RS-054
Canoeing	RS-079
Fishing Area	RS-063
Hand Launch/Small Boat Launch *	RS-117
Jet Ski/Personal Watercraft	RS-121
Marina *	RS-053
Motorboating	RS-055
Scuba Diving	RS-060
Seal Viewing	RS-106
Swimming	RS-061
Waterskiing	RS-058
Whale Viewing	RS-107

Services	
Electrical Hook-Up *	RS-150
First Aid *	RS-024
Laundromat *	RS-085
Picnic Shelter	RS-039
Picnic Site	RS-044
Post Office *	RS-026
Showers *	RS-035
Tramway	RS-071
Trash Dumpster *	RS-091

Winter Recreation	
Chair Lift/Ski Lift	RS-105
Cross Country Skiing	RS-046
Dog Sledding	RS-143
Sledding	RS-049
Snow Tubing	RS-144
Snowshoeing	RS-078
Winter Recreational Area	RS-077

* For use only within recreational and cultural interest areas where speed limits are 25 mph or less.

Guidance:

- 01 Recreational and cultural interest area symbol signs should be 24 x 24 inches. Where greater visibility or emphasis is needed, larger sizes should be used. Symbol sign enlargements should be in 6-inch increments.
- 02 Recreational and cultural interest area symbol signs should be 30 x 30 inches when used on guide signs on freeways or expressways.

Option:

- 03 A smaller size of 18 x 18 inches may be used on low-speed, low-volume roadways and on non-road applications.

Wayfinding Guide Signs

Community wayfinding guide signs are part of a coordinated and continuous system of signs that direct tourists and other road users to key civic, cultural, visitor and recreation attractions and other similar secondary destinations within a city or local urbanized or downtown area.

Community wayfinding guide signs are a type of destination guide sign for conventional roads with common color and/or identification marker for destinations within an overall wayfinding guide plan for an area.

Examples of a few Wayfinding Guide Signs manufactured by IPI

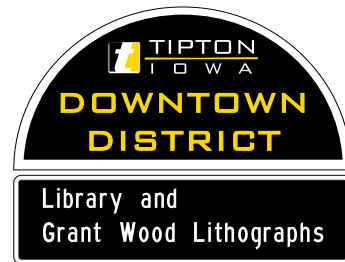
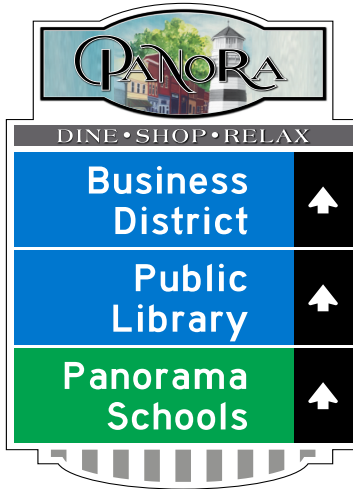

Type B Interstate Signs



IPI has the capabilities to manufacture Type B signage.
All Type B signage is manufactured per DOT approved specifications.

BUSINESS SIGN BLANK SPECIFICATIONS

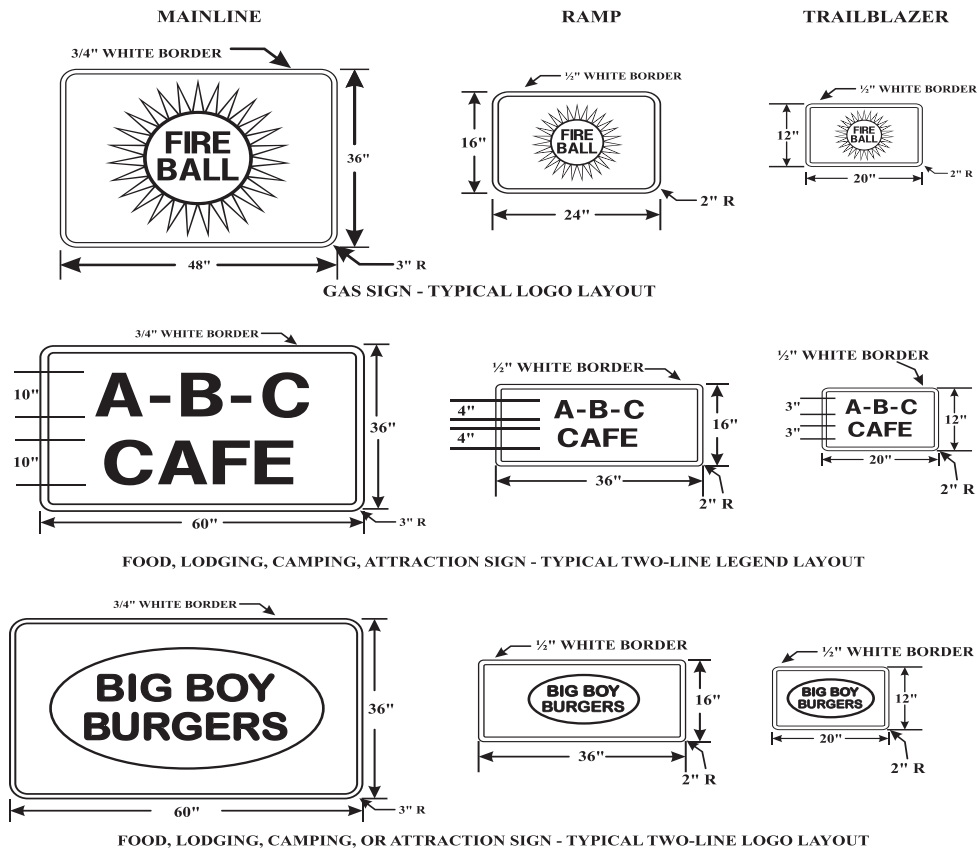

IPI can manufacture Logo Business Signs as shown above.
We build this type of sign per D.O.T. approved specification.

IPI SIGNS - FACES - DECALS

This section of our catalog provides a complete listing of our standard items and their sizes. Our product numbers as well as standard sizes available are listed.

A special size and colors can be substituted upon request. Unless it is noted in the sign illustration below that substitutions are standard and any special requests may entail an additional special sign charges.

IPI ADOPT-A-			
Sign	Part Description	Size	Specify choice
IPIA100	LITTER REMOVAL COURTESY OF	24X36	
IPIA101	(Specify) SPONSER 3 LINE maximum	24X18	Sponsor
IPIA102	WORKERS SYMBOL (Hinged sign)	24X24	



IPIA100



IPIA101

(Specify Sponsor)



IPIA102

IPI ROAD CLOSURE PANELS

Sign	Part Description	Size	
IPIB100L	Permanent Road Closure Panel Left	24X9	
IPIB100L	Permanent Road Closure Panel Left	48X9	
IPIB101R	Permanent Road Closure Panel Right	24X9	
IPIB101R	Permanent Road Closure Panel Right	48X9	



IPIB100L



IPIB100L



IPIB101R



IPIB101R

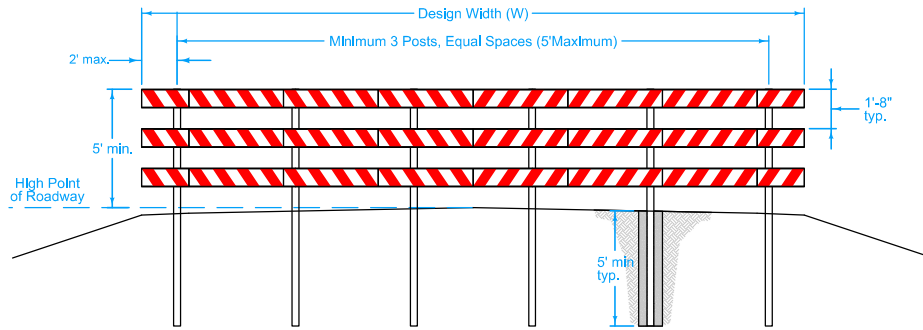

APPROACH VIEW

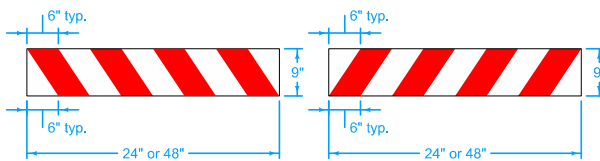

IA OC7-1AL: 24 IA OC7-1BL: 48
No Border, White; Red Diagonal

IA OC7-1AR: 24 IA OC7-1BR: 48
No Border, White; Red Diagonal

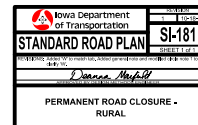

PERMANENT ROAD CLOSURE - RURAL

IPI Decals

Sign	Part Description	Size	Specify choice
IPID100	(Specify) in Shape of Iowa	18X12	Message on Non-Reflective decal
IPID100	(Specify) in Shape of Iowa	18X12	Message on Reflective decal
IPID100	(Specify) in Shape of Iowa	18X12	Message on Transparent decal
IPID100	(Specify) in Shape of Iowa	18X12	Message on Non-Reflective magnet
IPID101	DRIVER EDUCATION	24X6	Reflective decal OR Reflective magnet
IPID102	STUDENT DRIVER	24X6	Reflective decal OR Reflective magnet
IPID103	SCHOOL BUS	36X8	Reflective decal OR Reflective magnet
IPID200	ETHANOL	11X3	Ethanol Non-Reflective decal
IPID200	E10	11X3	E10 Non-Reflective decal
IPID200	E85	11X3	E85 Non-Reflective decal
IPID201	THIS VEHICLE USES ONLY E10	1-1/2" RND	E10 Non-Reflective decal
IPID201	THIS VEHICLE MUST USE E85	1-1/2" RND	E85 Non-Reflective decal
IPID300	AMERICAN FLAG SYMBOL	6X4	Waving Reflective decal
IPID300	AMERICAN FLAG SYMBOL	11X8	Waving Reflective decal
IPID300	AMERICAN FLAG SYMBOL	6X4	Reflective decal - facing LEFT
IPID300	AMERICAN FLAG SYMBOL	6X4	Reflective decal - facing RIGHT
IPID301	GOLF CART, ATV, UTV PERMIT (Specify)	4X2	Message/color layout required
IPID400	DEPARTMENT OF CORRECTIONS	13-1/2" RND	Black on Transparent decal
IPID400	DEPARTMENT OF CORRECTIONS	13-1/2" RND	White on Transparent decal

IPI Health & Safety Decals

IPIH302	NO SMOKING w/ SYMBOL	3" RND	Non-Reflective white decal
IPIH302	NO SMOKING w/ SYMBOL	8X3	Non-Reflective white decal
IPIH303	NO SMOKING w/ SYMBOL	3" RND	Reverse print-Transparent white decal
IPIH303	NO SMOKING w/ SYMBOL	8X3	Reverse print-Transparent white decal
IPIH304	NO SMOKING w/ SYMBOL	3" RND	Reverse print-Transparent decal
IPIH304	NO SMOKING w/ SYMBOL	8X3	Reverse print-Transparent decal
IPIH305	NO SMOKING w/ SYMBOL	3" RND	Reverse print-Transparent CLING decal
IPIH305	NO SMOKING w/ SYMBOL	8X3	Reverse print-Transparent CLING decal
IPIH401	NO WEAPONS ALLOWED w/ SYMBOL	4X6	Non-Reflective white decal
IPIH401	NO WEAPONS ALLOWED w/ SYMBOL	4X6	Reverse print-Transparent white decal
IPIH401	NO WEAPONS ALLOWED w/ SYMBOL	4X6	Reverse print-Transparent decal
IPIH401	NO WEAPONS ALLOWED w/ SYMBOL	4X6	Reverse print-Transparent CLING decal
IPIH402	No Weapons Allowed On (Specify) Property w/sym	4X6	Non-Reflective white decal
IPIH402	No Weapons Allowed On (Specify) Property w/sym	4X6	Reverse print-Transparent white decal
IPIH402	No Weapons Allowed On (Specify) Property w/sym	4X6	Reverse print-Transparent decal
IPIH402	No Weapons Allowed On (Specify) Property w/sym	4X6	Reverse print-Transparent CLING decal

IPI Decals



IPID100

(Specify Message)

DRIVER EDUCATION

IPID101

STUDENT DRIVER

IPID102

SCHOOL BUS

IPID103



IPID200

OR



IPID200

OR



IPID200



IPID201

OR



IPID201

IPI Decals



IPID300 (Size)
(Waving)

OR

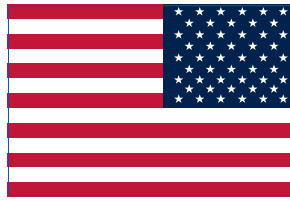

IPID300
(Left)

OR



IPID300
(Right)



IPID301
(Specify Message-Color)

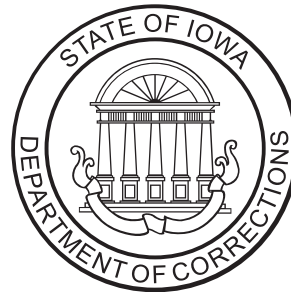

IPID400
(Specify Color)
(DOC use only)

IPI Health & Safety Decals



IPIH302

OR



IPIH302



IPIH401



IPIH402
(Specify Message)

IPI GUIDE

Sign	Part Description	Size	Specify choice
IPIG100	IOWA BYWAYS () SCENIC BYWAY	24X42	COVERED BRIDGES
IPIG100	IOWA BYWAYS () SCENIC BYWAY	24X42	DELAWARE CROSSING
IPIG100	IOWA BYWAYS () SCENIC BYWAY	24X42	DRIFTLESS AREA
IPIG100	IOWA BYWAYS () SCENIC BYWAY	24X42	GLACIAL TRAIL
IPIG100	IOWA BYWAYS () SCENIC BYWAY	24X42	GRANT WOOD
IPIG100	IOWA BYWAYS () SCENIC BYWAY	24X42	NATIONAL
IPIG100	IOWA BYWAYS () SCENIC BYWAY	24X42	HISTORIC HILLS
IPIG100	IOWA BYWAYS () SCENIC BYWAY	24X42	IOWA VALLEY
IPIG100	IOWA BYWAYS () HERITAGE BYWAY	24X42	JEFFERSON HIGHWAY
IPIG100	IOWA BYWAYS () HERITAGE BYWAY	24X42	LINCOLN HIGHWAY
IPIG100	IOWA BYWAYS () SCENIC BYWAY	24X42	LOESS HILLS NATIONAL
IPIG100	IOWA BYWAYS () SCENIC BYWAY	24X42	RIVER BLUFFS
IPIG100	IOWA BYWAYS () SCENIC BYWAY	24X42	WESTERN SKIES
IPIG100	IOWA BYWAYS () SCENIC BYWAY	24X42	WHITE POLE ROAD
IPIG102	IOWA GREAT PLACE	12X18	Size
IPIG102	IOWA GREAT PLACE	24X36	Size
IPIG103	Iowa Cultural & Entertainment District	12X18	Size
IPIG103	Iowa Cultural & Entertainment District	24X36	Size
IPIG104	REAP w/ GRAPHIC FUND BY	12X12	Ink Jet Non-Reflective
IPIG104	REAP w/ GRAPHIC FUND BY	12X12	Ink Jet Reflective
IPIG105	BIRD FRIENDLY IOWA COMMUNITY	24X30	
IPIG300	D.A.R.E. COMMUNITY	24X18	
IPIG301	NEIGHBORHOOD WATCH AREA	24X18	
IPIG500	DRAGOON TRAIL	30X30	
IPIG501	IOWA MORMON TRAILS	12X30	
IPIG700	(Specify) CITY LIMITS	VariesX12	Specify City Name, 12" Layout required
IPIG700	(Specify) CITY LIMITS	VariesX18	Specify City Name, 18" Layout required
IPIG701	(Specify) COUNTY LINE	VariesX18	Specify County Name, 18" Layout required



IPIG100



IPIG100

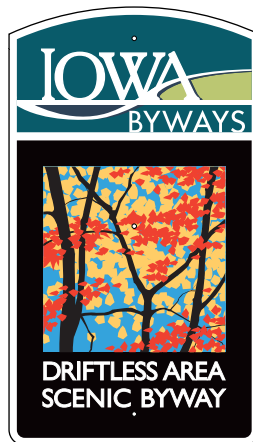

IPIG100

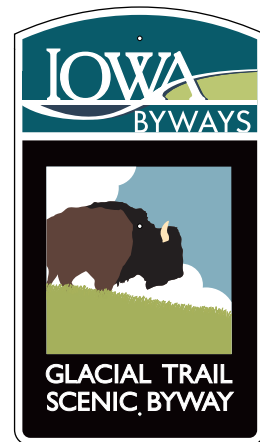

IPIG100

IPI GUIDE



IPIG100



IPIG100

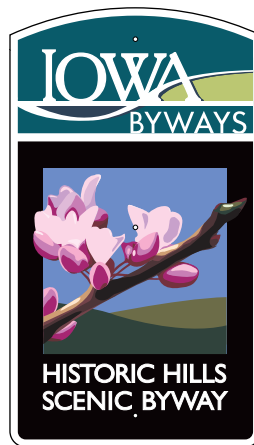

IPIG100



IPIG100



IPIG100



IPIG100

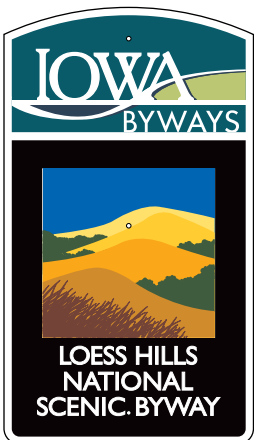

IPIG100

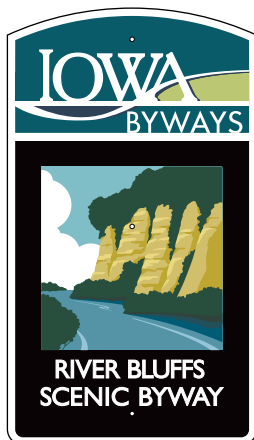

IPIG100



IPIG100

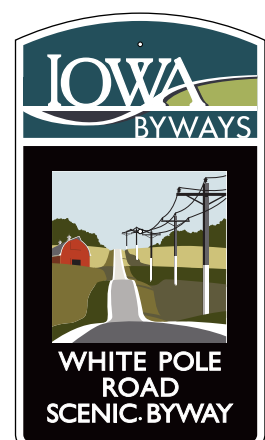

IPIG100

IPI GUIDE

(Requires Outside Agency Approval)



IPIG102 (Size)



IPIG103 (Size)



IPIG104



IPIG105



IPIG300



IPIG301



IPIG500



IPIG501



IPIG700 (Size)
(Specify City Name)

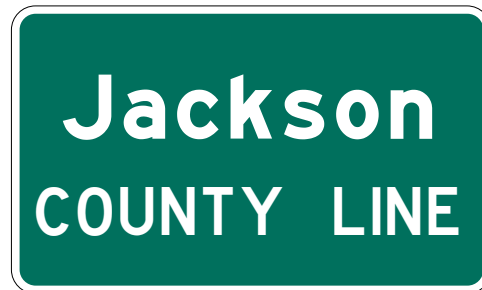

IPIG701
(Specify County Name)

IPI HEALTH & SAFETY

Sign	Part Description	Size	Specify choice
IPIH100	HAZARDOUS CHEMICAL PLAQUE	10X10	Leave blank
IPIH100	HAZARDOUS CHEMICAL PLAQUE (Specify)	10X10	Numbers & Symbols
	INDIVIDUAL NUMBERS ONLY (Specify)	3"C	Numbers
	INDIVIDUAL SYMBOLS ONLY (Specify)	4.5X4.5	Symbols
IPIH101	Signs not posted for all hazardous chemicals	48X12	
IPIH102	DANGER (Specify)	10X7	Message
IPIH102	DANGER (Specify)	14X10	Message
IPIH103	NOTICE (Specify)	10X7	Message
IPIH103	NOTICE (Specify)	14X10	Message
IPIH104	SLOW MOVING VEHICLE SYMBOL	14X14X14	
IPIH105	STAY BACK (Specify) FT.	24X12	Number
IPIH105	STAY BACK (Specify) FT.	36X4	Number
IPIH200	FIRE EXTINGUISHER w/ ARROW DOWN	4X24	
IPIH201	ENTER	14X8	
IPIH202	EXIT	14X8	
IPIH203	NOT AN EXIT	14X8	
IPIH300	NO SMOKING OR TOBACCO USE w/ SYMBOLS	12X12	
IPIH301	NO SMOKING w/ SYMBOL	12X12	
IPIH302	NO SMOKING w/ SYMBOL	3" RND	Non-Reflective white decal
IPIH302	NO SMOKING w/ SYMBOL	8X3	Non-Reflective white decal
IPIH303	NO SMOKING w/ SYMBOL	3" RND	Reverse print-Transparent white decal
IPIH303	NO SMOKING w/ SYMBOL	8X3	Reverse print-Transparent white decal
IPIH304	NO SMOKING w/ SYMBOL	3" RND	Reverse print-Transparent decal
IPIH304	NO SMOKING w/ SYMBOL	8X3	Reverse print-Transparent decal
IPIH305	NO SMOKING w/ SYMBOL	3" RND	Reverse print-Transparent CLING decal
IPIH305	NO SMOKING w/ SYMBOL	8X3	Reverse print-Transparent CLING decal
IPIH400	NO WEAPONS SYMBOL	12X12	
IPIH401	NO WEAPONS ALLOWED w/ SYMBOL	12X18	
IPIH401	NO WEAPONS ALLOWED w/ SYMBOL	4X6	Non-Reflective white decal
IPIH401	NO WEAPONS ALLOWED w/ SYMBOL	4X6	Reverse print-Transparent white decal
IPIH401	NO WEAPONS ALLOWED w/ SYMBOL	4X6	Reverse print-Transparent decal
IPIH401	NO WEAPONS ALLOWED w/ SYMBOL	4X6	Reverse print-Transparent CLING decal
IPIH402	No Weapons Allowed On (Specify) Property w/sym	12X18	
IPIH402	No Weapons Allowed On (Specify) Property w/sym	4X6	Non-Reflective white decal
IPIH402	No Weapons Allowed On (Specify) Property w/sym	4X6	Reverse print-Transparent white decal
IPIH402	No Weapons Allowed On (Specify) Property w/sym	4X6	Reverse print-Transparent decal
IPIH402	No Weapons Allowed On (Specify) Property w/sym	4X6	Reverse print-Transparent CLING decal
IPIH500	NO DRUGS SYMBOL w/ ZONE	18X24	Zone
IPIH500	NO DRUGS SYMBOL w/ ZONE INCREASED PENALTIES	18X24	Zone Increased Penalties
IPIH600	NOTICE w/ SYMBOL SECURITY CAMERAS IN USE	18X18	
IPIH601	This (Specify) Is Protected By Surveillance Cameras	12X18	Message

IPI Health & Safety

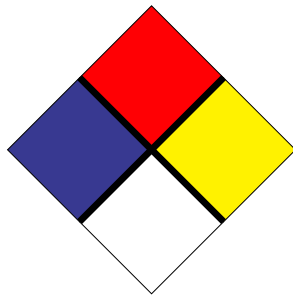

IPIH100
(Blank)

OR



IPIH100
(Specify # - Symbols)

0 1 2 3 4

FNUMBERCO3C-SCAL
(Specify Numbers)

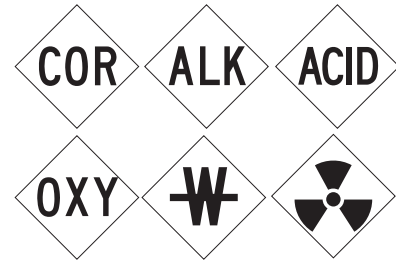

FSP-FACE
(Specify Symbols)



IPIH101



IPIH102 (Size)
(Specify Message)



IPIH103 (Size)
(Specify Message)



IPIH104



IPIH105
(Specify Number)

OR



IPIH105
(Specify Number)



IPIH200



IPIH201



IPIH202



IPIH203

IPI Health & Safety



IPIH300



IPIH301



IPIH302

(Decals)

OR



IPIH302



IPIH400



IPIH401

(Decal)



IPIH401



IPIH402

(Decal)



IPIH402

(Specify Message)



IPIH500

OR



IPIH500



IPIH600



IPIH601

(Specify Message)

IPI PARKS & RECREATION

Sign	Part Description	Size	Specify choice
IPIP100	LAND&WATER/BOR (Specify)	12X12	Sponsor name
IPIP100	LAND&WATER/BOR (Specify)	18X18	Sponsor name
IPIP100	LAND&WATER/BOR (Specify)	24X24	Sponsor name
IPIP101	CONSERVATION FARM (Specify)	24X18	Name & Sponsor
IPIP200	NO HUNTING (Specify)	12X18	County name
IPIP201	PUBLIC HUNTING (Specify)	12X18	County name
IPIP202	END OF COUNTY LAND	4X8	Face for back of sign
IPIP203	NATURAL RESOURCE AREA (Specify)	12X18	County name
IPIP204	WILDLIFE MANAGEMENT AREA (Specify)	12X18	County name
IPIP205	WILDLIFE REFUGE (Specify)	12X18	County name
IPIP206	(Specify) RESPECT PRIVATE PROPERTY	12X6	Message
IPIP207	(Specify) PRIVATE PROPERTY NO TRESPASSING	12X6	Message
IPIP300	IA FISH HABITAT PROGRAM	12X18	
IPIP301	PROJECT FUNDED BY (Specify)	12X6	Sponsor name
IPIP302	Bass Less Than 15" Must Be Released	18X24	
IPIP400	ARROWHEAD (Specify)	24X24	Message-Arrow direction layout required
IPIP400	ARROWHEAD (Specify)	24X36	Message-Arrow direction layout required
IPIP400	ARROWHEAD (Specify)	36X36	Message-Arrow direction layout required
IPIP400	ARROWHEAD (Specify)	36X48	Message-Arrow direction layout required
IPIP400	ARROWHEAD (Specify)	48X48	Message-Arrow direction layout required
IPIP400	ARROWHEAD (Specify)	48X60	Message-Arrow direction layout required
IPIP500	MEN RESTROOM SYMBOL	8X8	Brown OR Blue
IPIP500	MEN RESTROOM SYMBOL w/ MEN	8X8	Brown OR Blue
IPIP500	MEN RESTROOM ACCESSIBLE SYMBOL w/ MEN	8X8	Brown OR Blue
IPIP501	WOMEN RESTROOM SYMBOL	8X8	Brown OR Blue
IPIP501	WOMEN RESTROOM SYMBOL w/ WOMEN	8X8	Brown OR Blue
IPIP501	WOMEN RESTROOM ACCESSIBLE SYMBOL w/ WOMEN	8X8	Brown OR Blue
IPIP502	UNISEX RESTROOM SYMBOL	8X8	Brown OR Blue
IPIP502	UNISEX RESTROOM SYMBOL w/ UNISEX	8X8	Brown OR Blue
IPIP503	CARRY IN w/ SYMBOL CARRY OUT	12X18	
IPIP504	NO TRESPASSING	18X12	Color on White
IPIP505	NO PETS ALLOWED w/ SYMBOL	12X18	Black-Red-White
IPIP505	NO PETS ALLOWED w/ SYMBOL	12X18	Red-Black-White
IPIP506	NO PETS ALLOWED (Specify) w/ SYMBOL	12X18	Black-Red-White & message
IPIP506	NO PETS ALLOWED (Specify) w/ SYMBOL	12X18	Red-Black-White & message
IPIP507	NO PETS ALLOWED	12X18	Black-White
IPIP507	NO PETS ALLOWED	12X18	Red-White
IPIP508	CLEAN UP AFTER YOUR PET w/ SYMBOL	12X18	
IPIP509	RESERVED w/ Plexiglass slot	18X18	White-Brown
IPIP600	EMERGENCY LOCATION (Specify)	6X9	Numbers
IPIP600	EMERGENCY LOCATION (Specify)	9X12	Numbers
IPIP600	EMERGENCY LOCATION (Specify)	12X12	Numbers
IPIP700	NO MOTORIZED VEHICLES	12X18	
IPIP701	NO MOTORIZED VEHICLES BEYOND THIS POINT	12X18	
IPIP701	NO MOTORIZED VEHICLES BEYOND THIS POINT	18X24	
IPIP702	NO VEHICLES BEYOND THIS POINT	12X18	

IPI Parks & Recreation



IPIP100 (Size)
(Specify Sponsor)



IPIP101
(Specify Name & Sponsor)

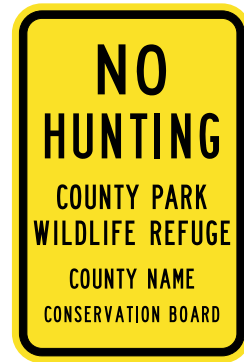

IPIP200
(Specify County)



IPIP201
(Specify County)



IPIP202



IPIP203
(Specify County)

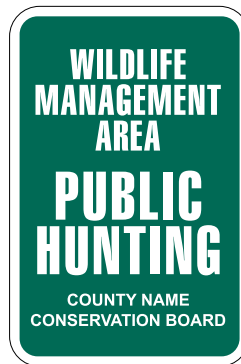

IPIP204
(Specify County)



IPIP205
(Specify County)



IPIP206
(Specify Message)



IPIP207
(Specify Message)

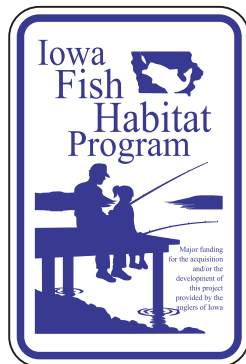

IPIP300



IPIP301
(Specify Sponsor)

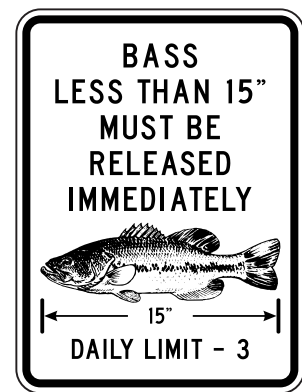

IPIP302

IPI Parks & Recreation



IPIP400 (Size)



IPIP400 (Size)

(Specify County, Arrow Direction, Miles-if any, Access & Layouts Required)



IPIP500

OR



IPIP500



IPIP500

OR



IPIP500



IPIP500

OR



IPIP500

IPI Parks & Recreation



IPIP501

OR



IPIP501



IPIP501

OR



IPIP501



IPIP501

OR



IPIP501



IPIP502

OR



IPIP502



IPIP502

OR



IPIP502



IPIP503



IPIP504



IPIP505

OR



IPIP505

(Specify Color on White)

IPI Parks & Recreation



IPIP506

OR



IPIP506



IPIP507

OR



IPIP507



IPIP508

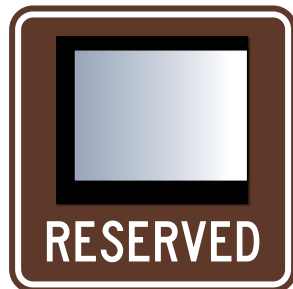

IPIP509

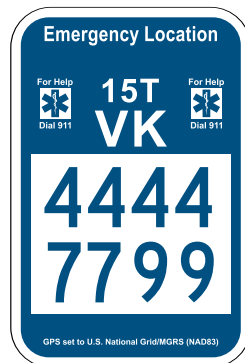

IPIP600 (Size)
(Specify Numbers)

OR



IPIP600 (Size)
(Specify Numbers)



IPIP700

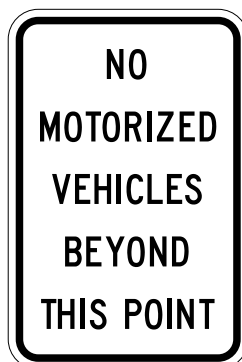

IPIP701 (Size)



IPIP702

IPI REGULATORY

Sign	Part Description	Size	Specify choice
IPIR100	REFLECTIVE STRIP RED	2X48	
IPIR100	REFLECTIVE STRIP RED	2X60	
IPIR100	REFLECTIVE STRIP RED	2X72	
IPIR101	REFLECTIVE STRIP WHITE	2X48	
IPIR101	REFLECTIVE STRIP WHITE	2X60	
IPIR101	REFLECTIVE STRIP WHITE	2X72	
IPIR102	ROW	4X9	
IPIR103	NO DUMPING ALLOWED	12X18	
IPIR103	NO DUMPING ALLOWED	18X24	
IPIR103	NO DUMPING ALLOWED	24X30	
IPIR104	DO NOT ENTER WHEN FLOODED	24X30	
IPIR105	NO TRESPASSING LEVEL C SERVICE LIMITED....	66X30	
IPIR300	(Specify) MINUTE PARKING	12X18	Number
IPIR301	(Specify) PARKING	12X18	Message
IPIR301	(Specify) (Specify) PARKING	12X18	Message
IPIR302	(Specify) PARKING (Specify)	12X18	Message
IPIR303	EMERGENCY SNOW ROUTE w/ SYMBOL	12X18	White-Blue-White
IPIR303	EMERGENCY SNOW ROUTE w/ SYMBOL	18X24	White-Blue-White
IPIR303	EMERGENCY SNOW ROUTE w/ SYMBOL	12X18	White-Red-White
IPIR303	EMERGENCY SNOW ROUTE w/ SYMBOL	18X24	White-Red-White
IPIR304	NO PARKING	12X18	
IPIR305	NO TRUCK PARKING	12X18	
IPIR306	2-WAY	12X6	
IPIR306	3-WAY	12X6	
IPIR306	4-WAY	12X6	
IPIR307	RESERVED PARKING w/ SYMBOL (Specify)	12X18	Arrow direction & Fine \$
IPIR308	PARKING ONLY w/ FINE (Specify)	12X18	Fine \$
IPIR308N	PARKING ONLY w/ NO FINE		
IPIR309	STATE PERMIT REQUIRED w/ FINE (Specify)	12X18	Fine \$
IPIR309N	STATE PERMIT REQUIRED w/ NO FINE		
IPIR310	VAN ACCESSIBLE w/ FINE (Specify)	12X18	Fine \$
IPIR310N	VAN ACCESSIBLE w/ NO FINE		
IPIR311	VAN ACCESSIBLE	12X6	
IPIR312	ELECTRIC VEHICLE CHARGING ONLY	12X18	
IPIR312	ELECTRIC VEHICLE PARKING ONLY	12X18	
IPIR312	SINGLE ARROW SYMBOL	12X6	Color on White
IPIR312	DOUBLE ARROW SYMBOL	12X6	Color on White
IPIR312	SINGLE ARROW SYMBOL	12X6	White on Color
IPIR312	DOUBLE ARROW SYMBOL	12X6	White on Color
IPIR500	ENGINE BRAKE ORDINANCE ENFORCED	18X24	
IPIR500	ENGINE BRAKE ORDINANCE ENFORCED	24X24	
IPIR501	END SPEED ZONE	24X30	
IPIR502	REDUCED SPEED AHEAD	18X24	
IPIR502	REDUCED SPEED AHEAD	24X30	
IPIR503	SPEED ZONE AHEAD	18X24	
IPIR503	SPEED ZONE AHEAD	24X30	
IPIR701	AHEAD	24X12	
IPIR702	ALL VEHICLES	24X12	
IPIR702	ALL VEHICLES	30X18	
IPIR703	PLEASE ALTERNATE	36X18	
IPIR704	RESTRICTED BRIDGE	30X18	
IPIR705	TRUCKS OVER(#) LBS OR (#) TONS...	72X42	
IPIR705	TRUCKS OVER(#) LBS OR (#) TONS...	84X48	

IPI Regulatory

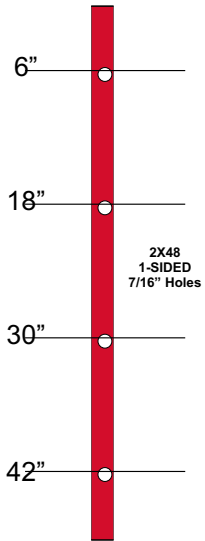

IPIR100 (Size)

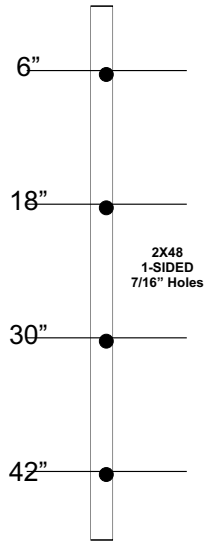

IPIR101 (Size)



IPIR102



IPIR103 (Size)



IPIR104



IPIR105



IPIR300

(Specify Number)



IPIR301

(Specify Message)

OR



IPIR301

(Specify Message)



IPIR302

(Specify Message)



IPIR303 (Size)

OR



IPIR303 (Size)



IPIR304



IPIR305

IPI Regulatory



OR



IPIR306

(Specify Number)

IPIR307

(Specify Arrow-Fine \$)



IPIR308

(Specify Fine \$)



IPIR308N



IPIR309

(Specify Fine \$)



IPIR309N



IPIR310

(Specify Fine \$)



IPIR310N



IPIR311

IPI Regulatory



IPIR312

OR



IPIR312

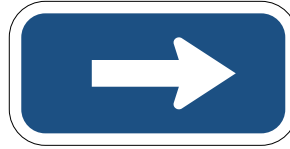

OR

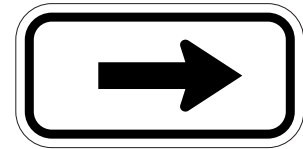

OR

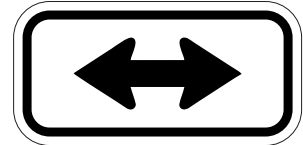

IPIR313

(Specify Single or Double Arrow & Color Combo)



IPIR500 (Size)



IPIR501

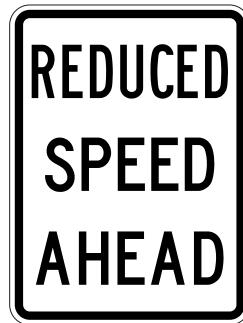

IPIR502 (Size)



IPIR503 (Size)



IPIR701



IPIR702 (Size)



IPIR703



IPIR704

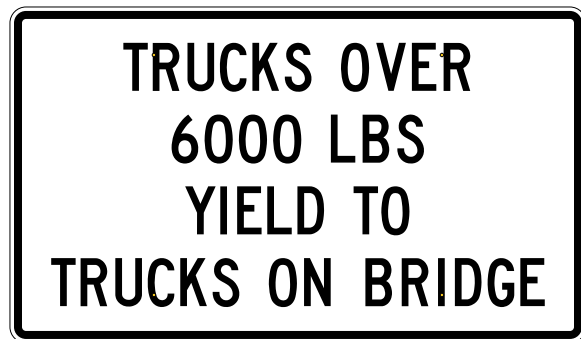

IPIR705 (Size)

IPI STENCIL

Sign	Part Description	Size	
IPIS100	WHEELCHAIR SYMBOL	48X48	.055 POLY

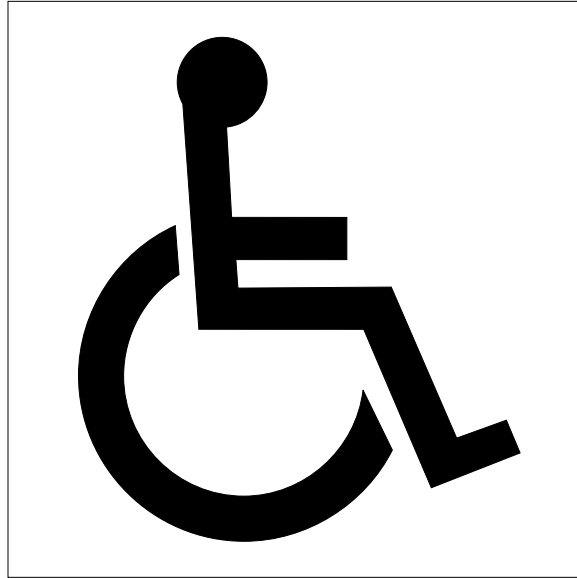

IPIS100

We can make other stencils at your request.

**CITY OF
LAKE MILL**

**ABC
123**

IPI WARNING

Sign	Part Description	Size	Specify choice
IPIW100	REFLECTIVE STRIP YELLOW	2X48	
IPIW100	REFLECTIVE STRIP YELLOW	2X60	
IPIW100	REFLECTIVE STRIP YELLOW	2X72	
IPIW101	REFLECTIVE STRIP YELLOW-GREEN	2X48	
IPIW101	REFLECTIVE STRIP YELLOW-GREEN	2X60	
IPIW101	REFLECTIVE STRIP YELLOW-GREEN	2X72	
IPIW300	CAUTION DEAF CHILD	18X24	
IPIW301	SLOW CHILDREN AT PLAY	18X24	
IPIW303	(Specify) CHILD AREA	24X24	DEAF, AUTISTIC or BLIND
IPIW303	(Specify) CHILD AREA	30X30	DEAF, AUTISTIC or BLIND
IPIW304	(Specify) DRIVEWAY	30X30	
IPIW305	CAUTION MINIMUM MAINTENANCE ROAD	30X30	
IPIW306	DANGEROUS INTERSECTION	30X30	
IPIW307	DIRT ROAD	30X30	
IPIW308	END (Specify) MAINTENANCE	36X18	CITY or COUNTY
IPIW309	FLOOD AREA AHEAD	30X30	
IPIW310	GRAVEL ENDS	30X30	
IPIW311	GRAVEL ENDS (Specify)	30X30	#FT, #MILES or AHEAD
IPIW312	IMPASSIBLE DURING HIGH WATER	30X30	
IPIW313	LEVEL B SERVICE ENTER AT YOUR OWN RISK	36X18	
IPIW315	MINIMUM MAINTENANCE ROAD AHEAD	30X30	
IPIW316	NO SNOW REMOVAL	30X30	
IPIW317	NOT A THROUGH STREET	30X30	
IPIW318	PRIVATE (Specify)	30X30	Message
IPIW321	ROCK ENDS	30X30	
IPIW322	ROCK ENDS (Specify)	30X30	#FT, #MILES or AHEAD
IPIW323	SLOW	24X24	
IPIW323	SLOW	30X30	Black on Yellow OR Black on Orange
IPIW323	SLOW	36X36	Black on Yellow OR Black on Orange
IPIW324	SURFACING ENDS	30X30	
IPIW325	TRUCKS ENTERING (Specify)	30X30	Message
IPIW325	TRUCKS ENTERING (Specify)	36X36	Message
IPIW326	WATCH FOR CHILDREN	30X30	
IPIW327	WATER OVER ROAD	24X24	
IPIW327	WATER OVER ROAD	30X30	Black on Yellow OR Black on Orange
IPIW327	WATER OVER ROAD	36X36	Black on Yellow OR Black on Orange
IPIW500	CHECK YOUR SPEED (Specify)	24X18	Number
IPIW501	LOW CLEARANCE	24X18	
IPIW700	WARNING BRIDGE AHEAD SAFE FOR ONE TRUCK ONLY	60X54	
IPIW900	DATE CODE STICKER (Specify)	3X2-1/2	County Name

IPI Warning

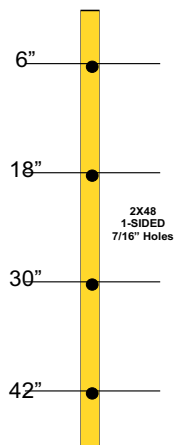

IPIW100 (Size)

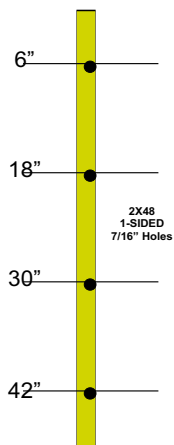

IPIW101 (Size)



IPIW300



IPIW301



IPIW303 (Size)
(Specify Message)



IPIW304
(Specify Message)



IPIW305



IPIW306



IPIW307



IPIW308

OR



IPIW308



IPIW309



IPIW310



IPIW311

Specify
AHEAD
FEET
MILES



IPIW312

IPI Warning

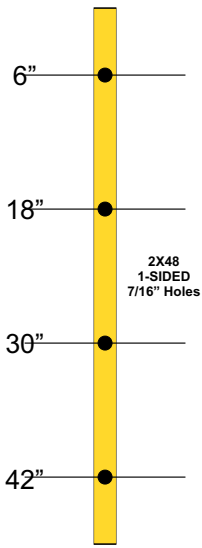

IPIW100 (Size)

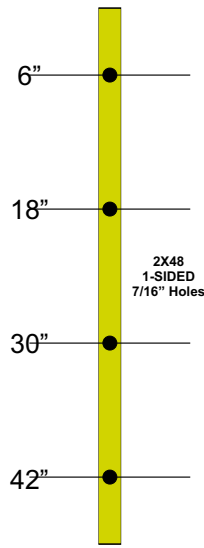

IPIW101 (Size)



IPIW300



IPIW301



IPIW303 (Size)
(Specify Message)



IPIW304



IPIW305



IPIW306



IPIW307



IPIW308



IPIW308

OR



IPIW309



IPIW310



IPIW311
(Specify Message)



IPIW312

IPI Warning



IPIW313



IPIW315



IPIW316



IPIW317



IPIW318
(Specify Message)



IPIW321



IPIW322
Specify
AHEAD
FEET
MILES



IPIW323 (Size)

OR



IPIW323 (Size)



IPIW324



IPIW325 (Size)
(Specify Message)



IPIW326



IPIW327 (Size)

OR



IPIW327 (Size)

IPI Warning



IPIW500

(Specify Number)



IPIW501



IPIW700



IPIW900

(Specify County Name)

Customized date code sticker per request require layouts for pricing



This section of our catalog provides a complete listing of the items and their sizes which we product following the specifications provided by the DNR. The DNR number as well as the standard sizes available are listed.

Public Access Signs

Sign	Part Description	Size	Note:
DNR001	MAP OF IOWA (SYMBOL)	18X12	Specify leave blank or message
DNR005	BLIND & DECOYS	12X10	
DNR010	PUBLIC HUNTING	12X18	DNR10A included on back of sign
DNR010A	END OF STATE LAND	4X8	
DNR011	PUBLIC ACCESS MISSOURI RIVER	12X18	DNR11A included on back of sign
DNR011A	END OF PUBLIC GROUND	4X8	
DNR012	STOP AQUATIC HITCHHIKERS	12X18	
DNR014	OPEN FOR PUBLIC... (2-SIDED)	12X18	2-sided (non-reflective)
DNR015	PUBLIC ACCESS (SPECIFY)	24X18	Specify leave blank or message
DNR017	DNR	17X11	Magnetic non-reflective decal
DNR017	DNR	17X11	Non-reflective decal
DNR017	DNR	4X2.5	Non-reflective decal
DNR019	FEDERAL AID PROJECT (SPECIFY)	36X24	Specify message
DNR020	WILDLIFE REFUGE	12X18	
DNR025	WILDLIFE MANAGEMENT AREA	12X18	
DNR027	NO SHOOTING OCCUPIED	12X18	
DNR034	BARRICADES 2-SIDED	18X4	2-Sided (Left one side Right other side)
DNR038	NO TRESPASS WATERFOWL REFUGE	12X18	
DNR040	WEAR IT w/ LIFE JACKET SYMBOL	12X12	
DNR041	PUBLIC WATERWAY	24X36	Sandbars and Riverbanks
DNR042	PUBLIC WATERWAY RIVERBANK	24X36	Private land
DNR043	OPEN FOR PUBLIC FISHING	12X18	Specify graphic (non-reflective)
DNR044	PLEASE FOLLOW IOWA FISHING	18X12	Specify message (non-reflective)
DNR045	AUTHORIZED VEHICLES ONLY	18X12	

Specialty sizes and colors can be substituted upon request but be aware that any substitution not listed in this catalog may not conform to DNR requirements. In addition, unless it is noted in the sign illustration below, "We insert any message here", any special requests may entail additional specialty sign charges.

Sign	Part Description	Size	Note:
DNR300	SNOWMOBILE NOT ALLOWED SYM	8X8	Reflective on .075 Poly
DNR301	SNOWMOBILE ALLOWED SYM	8X8	Reflective on .075 Poly
DNR303	ATVs NOT ALLOWED SYM	8X8	Reflective on .075 Poly
DNR304	ATVS ALLOWED SYMBOL	8X8	Reflective on .075 Poly
DNR305	STAY ON TRAIL	8X8	Reflective on .075 Poly
DNR306	STOP AHEAD SYMBOL	8X8	Reflective on .075 Poly
DNR307	YIELD AHEAD SYMBOL	8X8	Reflective on .075 Poly
DNR308	DO NOT ENTER	8X8	Reflective on .075 Poly
DNR309	TRAIL CLOSED	8X8	Reflective on .075 Poly
DNR310	YIELD	8X8	Reflective on .075 Poly
DNR311	STOP	8X8	Reflective on .075 Poly
DNR312	SINGLE ARROW	8X8	Reflective on .075 Poly
DNR313	T INTERSECTION SYMBOL	8X8	Reflective on .075 Poly
DNR314	KEEP RIGHT	8X8	Reflective on .075 Poly
DNR315	CAUTION	8X8	Reflective on .075 Poly
DNR316	CAUTION AHEAD	8X8	Reflective on .075 Poly
DNR317	SLOW	8X8	Reflective on .075 Poly
DNR318	TWO WAY TRAILS SYM	8X8	Reflective on .075 Poly
DNR319	BRIDGE SYMBOL	8X8	Reflective on .075 Poly
DNR320	TRAIL Y LEFT SYM	8X8	Reflective on .075 Poly
DNR321	TRAIL Y RIGHT SYM	8X8	Reflective on .075 Poly
DNR322	U-TURN LEFT SYM	8X8	Reflective on .075 Poly
DNR323	U-TURN RIGHT SYM	8X8	Reflective on .075 Poly
DNR324	UP - AND - OUT LEFT SYM	8X8	Reflective on .075 Poly
DNR325	UP - AND - OUT RIGHT SYM	8X8	Reflective on .075 Poly
DNR326	TRAIL CURVE LEFT SYM	8X8	Reflective on .075 Poly
DNR327	TRAIL CURVE RIGHT SYM	8X8	Reflective on .075 Poly
DNR328	SHARP LEFT TURN SYM	8X8	Reflective on .075 Poly
DNR329	SHARP RIGHT TURN SYM	8X8	Reflective on .075 Poly
DNR330	BRIDGE MARKER SYMBOL LEFT	5X8	Reflective on .075 Poly
DNR331	BRIDGE MARKER SYM RIGHT	5X8	Reflective on .075 Poly
DNR332	TRAIL DIAMOND (Orange Blazer)	5X7	Reflective on .075 Poly
DNR333	TRAIL DIAMOND (Green Blazer)	5X7	Reflective on .075 Poly
DNR334	KEEP LEFT	8X8	Reflective on .075 Poly
DNR335	RESPECT PRIVATE PROPERTY	8X8	Reflective on .075 Poly

DNR336	BRIDGE AHEAD	8X8	Reflective on .075 Poly
DNR337	WATCH FOR (PLOW SYMBOL)	8X8	Reflective on .075 Poly
DNR338	SLOW 5 MPH NO DUST	10X10	Reflective on .075 Poly
DNR339	TRAIL TEMPORARILY CLOSED	10X10	Reflective on .075 Poly
DNR340	STAY ON DESIGNATED ROUTES	10X10	Reflective on .075 Poly
DNR341	AREA CLOSED USE OTHER TRAIL	10X10	Reflective on .075 Poly
DNR342	TWO WAY TRAILS	8X8	Reflective on .075 Poly
DNR343	WRONG WAY	8X8	Reflective on .075 Poly
DNR344	CROSS ROAD SYMBOL	8X8	Reflective on .075 Poly
DNR345	PRACTICE TRACK	10X10	Reflective on .075 Poly
DNR346	TOT-LOT 100CC OR LESS	10X10	Reflective on .075 Poly
DNR347	NOTICE ALCOHOL IS NOT PERMIT..	10X10	Reflective on .075 Poly
DNR348	NO PARKING w/ DOUBLE ARROW	8X10	Reflective on .075 Poly
DNR349	PERIMETER TRAIL	9X6	Reflective on .075 Poly
DNR350	TRAILS MERGE	8X8	Reflective on .075 Poly

Sign	Part Description	Size	Note:
DNR400	WATER TRAIL (SPECIFY RIVER)	12X18	Specify River name
DNR401	LAUNCH ID (#) AND DISTANCE (#)	12X12	Specify numbers
DNR402	ON WATER LAUNCH SIGN (#)	24X18	Specify number
DNR403	CAMPSITE w/ TENT SYMBOL	12X12	
DNR404	NO CAMPING w/ SLASH SYMBOL	12X12	
DNR405	PICNIC AREA w/ TABLE SYMBOL	12X12	
DNR406	HIKING w/ HIKING SYMBOL	12X12	
DNR407	REST ROOM w/ UNISEX SYMBOL	12X12	
DNR408	EARLY WARNING (ON WATER)	Varies	Specify message - (Sign size determined below)
DNR409	PEDESTRIAN DROWNING ZONE	18X24	
DNR410	LAST LANDING ABOVE (ON WATER)	Varies	Specify message - (Sign size determined below)
DNR411	LAST LANDING ABOVE (ON LAND)	Varies	Specify message - (Sign size determined below)
DNR412A	PORTAGE TRAIL w/ ARW UP & SYM	8X8	
DNR412L	PORTAGE TRAIL w/ ARW LT & SYM	8X8	
DNR412R	PORTAGE TRAIL w/ ARW RT & SYM	8X8	
DNR413	WATER TRAIL RULES	12X12	
DNR414	MOVE LEFT/RIGHT (ON WATER)	Varies	Specify message - (Sign size determined below)
DNR415	WATER TRAIL SYMBOL	12X12	
DNR415	WATER TRAIL SYMBOL	24X24	
DNR416	BRIDGE (Layout Required)	VariesX18	Specify 2 line message
DNR416	BRIDGE (Layout Required)	VariesX24	Specify 3 line message
DNR417	BOAT NAVIGATION SINGLE ARROW	12X12	
DNR419	ACCESS POINT ID (#)	24X18	Specify number
DNR420A	(SPECIFY) MI - (SPECIFY) ARROW	24X18	Specify number & arrow direction
DNR420B	SINGLE ARROW	12X6	
DNR420B	SINGLE ARROW	24X12	
DNR421	LAST SAFE EXIT (ON WATER)	Varies	Specify message - (Sign size determined below)
DNR422	DAM	Varies	(Sign size determined below)
FSP-SIGN	OTHER HAZARDS SIGN (Specify)	Varies	Specify message - (Sign size determined below)

Public Access Signs



DNR001

Specify Leave Blank

OR

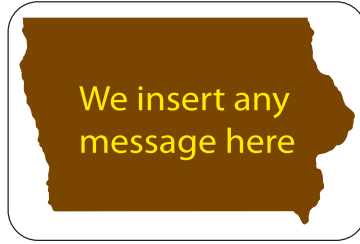

DNR001

Specify Message

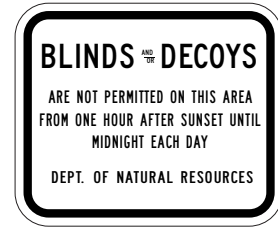

DNR005



DNR010



DNR010A



DNR011



DNR011A



DNR012

2-sided



DNR014



DNR015

Specify Leave Blank

OR



DNR015

Specify Message



DNR019

Specify Message



DNR017

Public Access Signs



DNR020



DNR025

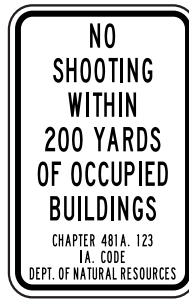

DNR027



DNR030

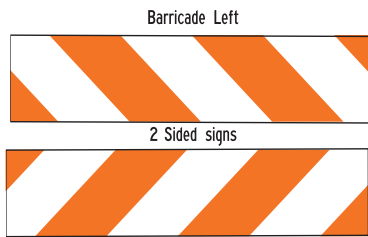

DNR034

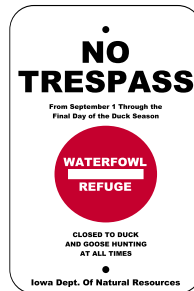

DNR038



DNR040



DNR041



DNR042



DNR043

Specify Graphic

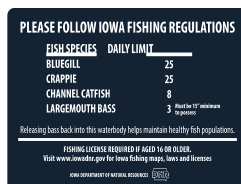

DNR044

Specify Message



DNR045

Trail Signs

Sign	Part Description	Size	Note:
DNR300	SNOWMOBILE NOT ALLOWED SYM	8X8	Reflective on .075 Poly
DNR301	SNOWMOBILE ALLOWED SYM	8X8	Reflective on .075 Poly
DNR303	ATVs NOT ALLOWED SYM	8X8	Reflective on .075 Poly
DNR304	ATVS ALLOWED SYMBOL	8X8	Reflective on .075 Poly
DNR305	STAY ON TRAIL	8X8	Reflective on .075 Poly
DNR306	STOP AHEAD SYMBOL	8X8	Reflective on .075 Poly
DNR307	YIELD AHEAD SYMBOL	8X8	Reflective on .075 Poly
DNR308	DO NOT ENTER	8X8	Reflective on .075 Poly
DNR309	TRAIL CLOSED	8X8	Reflective on .075 Poly
DNR310	YIELD	8X8	Reflective on .075 Poly
DNR311	STOP	8X8	Reflective on .075 Poly
DNR312	SINGLE ARROW	8X8	Reflective on .075 Poly
DNR313	T INTERSECTION SYMBOL	8X8	Reflective on .075 Poly
DNR314	KEEP RIGHT	8X8	Reflective on .075 Poly
DNR315	CAUTION	8X8	Reflective on .075 Poly
DNR316	CAUTION AHEAD	8X8	Reflective on .075 Poly
DNR317	SLOW	8X8	Reflective on .075 Poly
DNR318	TWO WAY TRAILS SYM	8X8	Reflective on .075 Poly
DNR319	BRIDGE SYMBOL	8X8	Reflective on .075 Poly
DNR320	TRAIL Y LEFT SYM	8X8	Reflective on .075 Poly
DNR321	TRAIL Y RIGHT SYM	8X8	Reflective on .075 Poly
DNR322	U-TURN LEFT SYM	8X8	Reflective on .075 Poly
DNR323	U-TURN RIGHT SYM	8X8	Reflective on .075 Poly
DNR324	UP - AND - OUT LEFT SYM	8X8	Reflective on .075 Poly
DNR325	UP - AND - OUT RIGHT SYM	8X8	Reflective on .075 Poly
DNR326	TRAIL CURVE LEFT SYM	8X8	Reflective on .075 Poly
DNR327	TRAIL CURVE RIGHT SYM	8X8	Reflective on .075 Poly
DNR328	SHARP LEFT TURN SYM	8X8	Reflective on .075 Poly
DNR329	SHARP RIGHT TURN SYM	8X8	Reflective on .075 Poly
DNR330	BRIDGE MARKER SYMBOL LEFT	5X8	Reflective on .075 Poly
DNR331	BRIDGE MARKER SYM RIGHT	5X8	Reflective on .075 Poly
DNR332	TRAIL DIAMOND (Orange Blazer)	5X7	Reflective on .075 Poly
DNR333	TRAIL DIAMOND (Green Blazer)	5X7	Reflective on .075 Poly
DNR334	KEEP LEFT	8X8	Reflective on .075 Poly
DNR335	RESPECT PRIVATE PROPERTY	8X8	Reflective on .075 Poly

Trail Signs

DNR336	BRIDGE AHEAD	8X8	Reflective on .075 Poly
DNR337	WATCH FOR (PLOW SYMBOL)	8X8	Reflective on .075 Poly
DNR338	SLOW 5 MPH NO DUST	10X10	Reflective on .075 Poly
DNR339	TRAIL TEMPORARILY CLOSED	10X10	Reflective on .075 Poly
DNR340	STAY ON DESIGNATED ROUTES	10X10	Reflective on .075 Poly
DNR341	AREA CLOSED USE OTHER TRAIL	10X10	Reflective on .075 Poly
DNR342	TWO WAY TRAILS	8X8	Reflective on .075 Poly
DNR343	WRONG WAY	8X8	Reflective on .075 Poly
DNR344	CROSS ROAD SYMBOL	8X8	Reflective on .075 Poly
DNR345	PRACTICE TRACK	10X10	Reflective on .075 Poly
DNR346	TOT-LOT 100CC OR LESS	10X10	Reflective on .075 Poly
DNR347	NOTICE ALCOHOL IS NOT PERMIT..	10X10	Reflective on .075 Poly
DNR348	NO PARKING w/ DOUBLE ARROW	8X10	Reflective on .075 Poly
DNR349	PERIMETER TRAIL	9X6	Reflective on .075 Poly
DNR350	TRAILS MERGE	8X8	Reflective on .075 Poly



DNR300



DNR301



DNR303



DNR304



DNR305



DNR306



DNR307



DNR308



DNR309



DNR310



DNR311



DNR312

Trail Signs



DNR313



DNR314



DNR315



DNR316



DNR317



DNR318

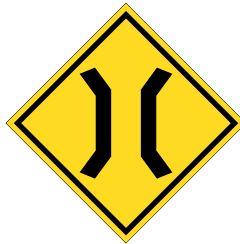

DNR319



DNR320



DNR321



DNR322



DNR322



DNR323



DNR324



DNR325



DNR326



DNR327



DNR328



DNR330



DNR331

Trail Signs

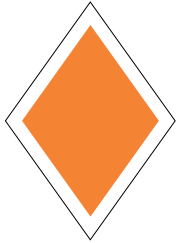

DNR332

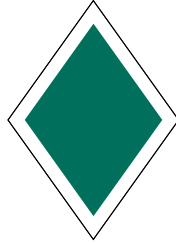

DNR333



DNR334



DNR335



DNR336



DNR337



DNR338



DNR339



DNR340



DNR341



DNR342



DNR343



DNR344



DNR345

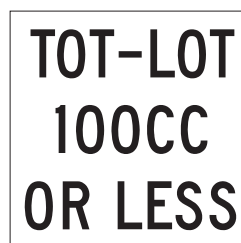

DNR346



DNR347



DNR348



DNR349



DNR350

Water Trail Signs

Water trails signage includes all signs associated with wayfinding, navigation, and use information viewed from both on-land and on-water. Users should be able to drive to the water trail launches they seek, as well as understand their locations while on-water.

Iowa's water trails program provides the mechanism and the challenge to create seamless recreational experiences for users across jurisdiction. Locations on state-designated trails, therefore, are identified with river mile numbers, much like the Interstate Highway System. Each launch location references both an access number, representing the river mile where the launch is located, and the launches formal name, such as Pickett's Access. River miles are calculated beginning with 0 (zero) at the mouth of a stream and progressing upstream. Consecutive numbering stops at Iowa state boundary limits.

Sign	Part Description	Size	Note:
DNR400	WATER TRAIL (SPECIFY RIVER)	12X18	Specify River name
DNR401	LAUNCH ID (#) AND DISTANCE (#)	12X12	Specify numbers
DNR402	ON WATER LAUNCH SIGN (#)	24X18	Specify number
DNR403	CAMPSITE w/ TENT SYMBOL	12X12	
DNR404	NO CAMPING w/ SLASH SYMBOL	12X12	
DNR405	PICNIC AREA w/ TABLE SYMBOL	12X12	
DNR406	HIKING w/ HIKING SYMBOL	12X12	
DNR407	REST ROOM w/ UNISEX SYMBOL	12X12	
DNR408	EARLY WARNING (ON WATER)	Varies	Specify message - (Sign size determined below)
DNR409	PEDESTRIAN DROWNING ZONE	18X24	
DNR410	LAST LANDING ABOVE (ON WATER)	Varies	Specify message - (Sign size determined below)
DNR411	LAST LANDING ABOVE (ON LAND)	Varies	Specify message - (Sign size determined below)
DNR412A	PORTAGE TRAIL w/ ARW UP & SYM	8X8	
DNR412L	PORTAGE TRAIL w/ ARW LT & SYM	8X8	
DNR412R	PORTAGE TRAIL w/ ARW RT & SYM	8X8	
DNR413	WATER TRAIL RULES	12X12	
DNR414	MOVE LEFT/RIGHT (ON WATER)	Varies	Specify message - (Sign size determined below)
DNR415	WATER TRAIL SYMBOL	12X12	
DNR415	WATER TRAIL SYMBOL	24X24	
DNR416	BRIDGE (Layout Required)	VariesX18	Specify 2 line message
DNR416	BRIDGE (Layout Required)	VariesX24	Specify 3 line message
DNR417	BOAT NAVIGATION SINGLE ARROW	12X12	
DNR419	ACCESS POINT ID (#)	24X18	Specify number
DNR420A	(SPECIFY) MI - (SPECIFY) ARROW	24X18	Specify number & arrow direction
DNR420B	SINGLE ARROW	12X6	
DNR420B	SINGLE ARROW	24X12	
DNR421	LAST SAFE EXIT (ON WATER)	Varies	Specify message - (Sign size determined below)
DNR422	DAM	Varies	(Sign size determined below)
FSP-SIGN	OTHER HAZARDS SIGN (Specify)	Varies	Specify message - (Sign size determined below)

Water Trail Signs

SIGN LETTER HEIGHT CALCULATIONS

Criteria used to size all aspects of signs viewed from the water are related to river width at the sign location and includes text height, sign panel size, and text spacing. Text is based on a modified version of the Army Corps of Engineers sign manual standards. The minimum text height for the main message for all water-viewed signs is 4 inches, regardless of river width. The font for all text is Arial.

Begin calculations for text height by determining river width where each sign is to be located. Width can be measured on the Iowa DNR Interactive Mapping Site using aerial photographs (www.iowadnr.gov/mapping/index.html).

The formula for calculating text height is illustrated on the right. Figure 6B-3 and Table 6B-1 are provided to calculate the 20/40 vision viewing distance (V). This value is used to calculate the height of the capital letter text (A) that would be legible from the viewing distance. The sign panel size is then determined based on proportions of the capital letter height and text-spacing requirements.

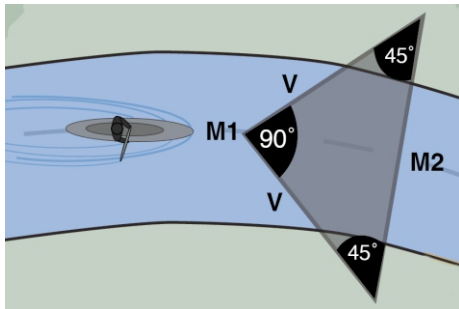

$$V \text{ (ft)} = (M1 - M2) / \cos 45^\circ$$

$$M1 - M2 = 0.5 \text{ river width (ft) (for } 45^\circ \text{ only)}$$

$$V \text{ (ft)} = (0.5 \text{ river width (ft)}) / 0.707$$

$$A \text{ (in)} = V28$$

$$20/40 A \text{ (in)} \times 0.50 = 20/20 A \text{ (in)}$$

$$20/40 A \text{ (in)} \times 0.75 = 20/30 A \text{ (in)}$$

(Always round up to nearest inch.)

Figure 6B-3.
Calculating Viewing Distance
Based on River Width

Table 6B-1.
Capital Letter Height for 20/40 Vision (Required
for all drowning zone signs)

20/40-VISION CHART FOR DROWNING ZONE SIGNS					
River Width (ft)	Capital Letter Height (in)	River Width (ft)	Capital Letter Height (in)	River Width (ft)	Capital Letter Height (in)
0-158	4	791-830	21	1464-1503	38
159-197	5	831-870	22	1504-1543	39
198-236	6	871-909	23	1544-1582	40
237-276	7	910-949	24	1583-1622	41
277-315	8	950-988	25	1623-1661	42
316-355	9	989-1028	26	1662-1701	43
356-395	10	1029-1068	27	1702-1741	44
396-434	11	1069-1107	28	1742-1780	45
435-474	12	1108-1147	29	1781-1820	46
475-513	13	1148-1186	30	1821-1859	47
514-553	14	1187-1226	31	1860-1899	48
554-592	15	1227-1266	32	1900-1939	49
593-632	16	1267-1305	33	1940-1978	50
633-672	17	1306-1345	34	1979-2018	51
673-711	18	1346-1384	35	2019-2057	52
712-751	19	1385-1424	36	2058-2097	53
752-790	20	1425-1463	37	2098-2137	54

Drowning Zone signs use 20/40 vision standards. In most other locations, 20/20 vision signs are sufficient, as field testing shows they are visible across the river's width. However, larger 20/30 vision signs are recommended in settings where high-speed motorized boat traffic is common, or where local land managers determine a high hazard.

Water Trail Signs

Table 6B-2.

Capital Letter Height for 20/30 Vision (Optional when greater visibility is desired)

20/30-VISION CHART FOR DROWNING ZONE SIGNS

River Width (ft)	Capital Letter Height (in)	River Width (ft)	Capital Letter Height (in)	River Width (ft)	Capital Letter Height (in)
0-197	4	1029-1107	21	1940-1978	38
198-236	5	1108-1147	22	1979-2057	39
237-315	6	1148-1186	23	2058-2097	40
316-355	7	1187-1266	24	2098-2137	41
356-395	8	1267-1305	25	2138-2216	42
396-474	9	1306-1345	26	2217-2255	43
475-513	10	1346-1424	27	2256-2295	44
514-553	11	1425-1463	28	2296-2374	45
554-632	12	1464-1503	29	2375-2414	46
633-672	13	1504-1582	30	2415-2453	47
673-711	14	1583-1622	31	2454-2492	48
712-790	15	1623-1661	32	2493-2572	49
791-830	16	1662-1741	33	2573-2612	50
831-870	17	1742-1780	34	2613-2651	51
871-949	18	1781-1820	35	2652-2731	52
950-988	19	1821-1899	36	2732-2770	53
989-1028	20	1900-1939	37	2771-2810	54

Table 6B-3.

Capital Letter Height for 20/20 Vision (Appropriate for most settings, with the exception of drowning zone signs)

20/20-VISION CHART FOR DROWNING ZONE SIGNS

River Width (ft)	Capital Letter Height (in)	River Width (ft)	Capital Letter Height (in)	River Width (ft)	Capital Letter Height (in)
0-315	4	1583-1661	21	2881-2958	38
316-395	5	1662-1741	22	2959-3036	39
396-475	6	1742-1820	23	3037-3114	40
476-553	7	1821-1899	24	3115-3192	41
554-632	8	1900-1978	25	3193-3271	42
633-711	9	1979-2057	26	3272-3349	43
712-790	10	2058-2137	27	3350-3427	44
791-870	11	2138-2176	28	3428-3505	45
871-949	12	2177-2254	29	3506-3583	46
950-1028	13	2255-2332	30	3584-3662	47
1029-1107	14	2333-2410	31	3663-3740	48
1108-1186	15	2411-2489	32	3741-3818	49
1187-1186	16	2490-2567	33	3819-3896	50
1267-1345	17	2568-2645	34	3897-3974	51
1346-1424	18	2646-2723	35	3975-4053	52
1425-1503	19	2724-2801	36	4054-4131	53
1504-1582	20	2802-2880	37	4132-4209	54

Water Trail Signs



DNR400

Specify River



DNR401

Specify Numbers



DNR402

Specify Number



DNR403



DNR404

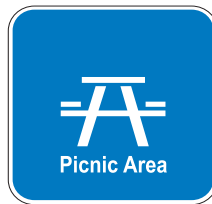

DNR405



DNR406



DNR407



DNR408

Specify Message
Layouts Required



DNR409

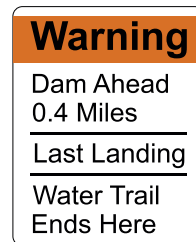

DNR410

Specify Message
Layouts Required



DNR411

Specify Message
Layouts Required



DNR412A

OR



DNR412L

OR



DNR412R

Water Trail Signs



DNR413

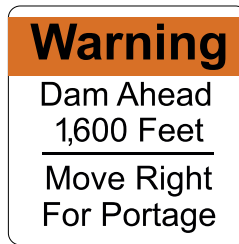

DNR414

Specify Message
 Layouts Required



DNR415

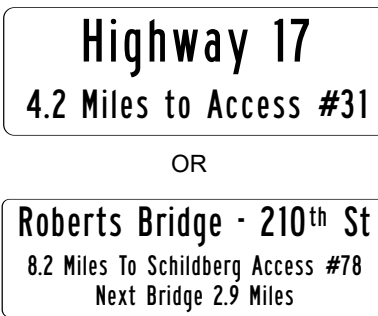

DNR416

Specify Message
 Layouts Required

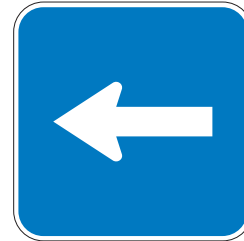

DNR417



DNR419

Specify Number



DNR420A

Specify Number / Arrow Direction



DNR420B



DNR421

Specify Number / Arrow direction
 Layouts Required



DNR422

Specify Size



FSP-SIGN

Specify Message
 Layouts Required

Decals, Banners, Signs & other Inkjet Items

Iowa Prison Industries manufactures a variety of decals, both for inventory and special orders. All IPI decals are made from highest quality 3M sheeting materials and meet all requirements for reflectivity and brightness. These materials are available in a wide array of solid colors, metallic colors, clear-transparent, static cling clear and films.

We can print and/or cut large or small color prints for signs, banners, or decals. Decals are also available with a magnetic backing. Photographs and/or custom designs in high resolution output in any of over a million colors can be done in large or small sizes. In addition, we have the capability to cut our your decal or sign design in any shape you require.

We can do one or two sided banners as wide as 50" in almost unlimited lengths. Let us know how long you wish to print your banner and we will most likely be able to accommodate you.

We can also print perforated window film, wrap film, safety vinyl, floor vinyl, sidewalk non-reflective, photo paper, posters, corrugated, poly, 6 mm panel and other materials.

For an estimate, send us a sketch, photograph or sample of your design.

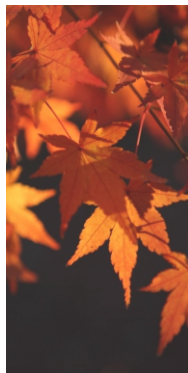

Iowa Sheriff Vehicle Markings



FDCALIASET3
or
FDCALIASET5



FDCALIASETTRUCK3
or
FDCALIASETTRUCK5



FDCALIASET3-WH
or
FDCALIASET5-WH



FDCALIASETTRUCK3-WH
or
FDCALIASETTRUCK5-WH



FDCALIASET3-BK
or
FDCALIASET5-BK



FDCALIASETTRUCK3-BK
or
FDCALIASETTRUCK5-BK

Go to the IPI Website at www.iaprisoinnd.com for ordering and /or more information on individual sheriff decal sales.

Sheeting & Substrate Information

Available Sheeting:

3M(TM) *Engineer Grade Prismatic (Standard Warranty - 7 years):*

An enclosed lens reflective sheeting with pressure sensitive adhesive backing for application to directional and route signage, off-road signage such as parking lots, handicap signs, etc. Meets ASTM D 4956 Spec Type I, Class 1.

3M(TM) *High-Intensity Prismatic Grade (Standard Warranty - 10 years):*

Non-metalized microprismatic lens reflective sheeting designed for production of reflective durable traffic control signs, work zone devices and delineators that are exposed vertically in service. Its unique prismatic construction provides a high level of retroreflectivity for multiple traffic control situations. Meets ASTM D4956 Type III, Type IV, and Type X specifications.

3M(TM) *Diamond Grade(TM) Cubed (Standard Warranty - 12 years):*

Highly reflective, durable, microprismatic lens sheeting with pressure sensitive adhesive. Performs at all sight distances – short, medium and long – and where signs are positioned in disadvantage locations such as overhead or left shoulder. Signs are highly visible even in visually complex nighttime roadway environments. Exceeds ASTM D 4956 Proposed Type XI specifications.

3M(TM) *Diamond Grade (TM) Cubed Fluorescent Yellow and Fluorescent Yellow Green (Standard Warranty - 12 years):*

Highly reflective, durable, microprismatic lens sheeting with pressure sensitive adhesive. Highly visible in daytime, twilight and inclement weather as well as night. Performs at wide entrance and observation angles. Exceeds ASTM D 4956 Type XI specifications.

Inkjet Reflective (Standard Warranty - Signs 5 years, Decals 3 years):

Durable, flexible, removable enclosed lens reflective film that features positionable, pressure activated adhesive and Comply™ Performance for easier, high quality installations. Removable up to 8 years.

Inkjet Non-Reflective (Standard Warranty - Signs 5 years, Decals 3 years):

Durable, flexible, removable enclosed lens film that features positionable, pressure activated adhesive and Comply™ Performance for easier, high quality installations. Removable up to 8 years.

3M(TM) *Reflective Graphic Film (Controltac):*

Create colorful, long term graphics for vehicles, signs and striping. Similar daytime and nighttime appearance. This film features 3M's repositionable, pressure activated adhesive to aid in large graphic application.

Vandal Proof Overlay is available for most signs.

“3M” is a registered trademark of 3M Company.

SUBSTRATES:

Aluminum signs available in gauges .080& .125.

Aluminum meets requirements of ASTM B-209, alloy 5052-H38 or 6061-T6.

Also available are Plywood, and Plastic for sign backings.

Ordering Process

Our goal is to provide you a quality product free of errors or delays. Orders can be placed by e-mail, fax, phone, or online at www.iaprisoinind.com. We have also included a blank order form for your ordering convenience. An acknowledgement of the order will be sent to the account billing address once the order is entered. Please review this acknowledgment to ensure accuracy.

As with any of our products, if you have questions, feel free to contact us. Our customer service representatives are there to help you get the product you want.

Signs shown in this catalog are considered to be standard signs. We are happy to quote any non-standard or special sign requirement you have. Special/Non-standard signs cannot be returned.

To help ensure you are receiving the product you want, please provide the following information:

Standard Signs

Account Name and Billing Address

Shipping Address

Contact Name, Contact Phone, Fax and E-mail address

Sign Catalog Number or MUTCD Number

Size of sign & shape: Width x Height, examples: diamond shaped, rectangular or square

Substrate type: .080", .125" Aluminum, HDO Plywood or other Substrates

Sheeting type-Examples are: Engineer Grade Prismatic, High Intensity Prismatic, and Diamond Grade Cubed. We also offer digital printing on clear, reflective and non-reflective material.

Sign color and text color

Sign message

One or two sided sign.

Standard specifications for radius and punch will be used. Please provide specifications for any other special radius and punch preference.

Street marker radius and punch specifications if we don't have your specifications on file.

Quantity discounts for multiple signs and free shipping may apply.

Special Signs

Special signs or larger orders should be in writing including any special specification. Please provide the above listed information for standard signs and in addition any artwork for your special sign.

You may provide drawings or electronic files in many formats – the preferred formats include:

CorelDraw - .CDR

Adobe Illustrator - .AI

Adobe Photoshop - .PSD

Tag Image File Format - .TIF

JPEG File Interchange Format - .JPG

Graphics Interchange Format - .GIF,

PC Paintbrush - .PCX

Portable Network Graphics - .PNG

(Instructions for Design Request) for further information and a complete list of files that IPI can open and work from.

A design layout is provided upon your request and 2 revisions are provided at no extra charge.

Terms and Conditions of Sale

An order acknowledgement will be sent when your order has been placed. Please review your acknowledgement upon receipt and notify the customer service office of any discrepancies.

When you receive your order, check all merchandise carefully. If merchandise arrives in less than a satisfactory condition make a notation on the carrier delivery ticket.

**items missing when checked against the packing list

**possibly damaged during shipping

Shortages or damaged merchandise must be filed with the delivering carrier within five (5) days after receiving goods. Claims for loss, damage or transportation charges must not be deducted from our invoice. Discrepancies found should be noted in writing on carrier delivery ticket and your copy of the delivery ticket. It is important that the driver signs both copies of the delivery ticket acknowledging the discrepancy. Please follow-up by notifying customer service at 1-800-336-5863 immediately. If you find further damage after delivery of goods, contact the delivering carrier immediately and request the carrier to make an inspection report.

Merchandise may NOT be returned without Iowa Prison Industries approval. Goods returned without authorization will be refused and returned at the sender's expense. Authorized return of merchandise must be carefully packaged so it reaches us in resalable condition. Merchandise returned in damaged condition due to improper packing will not be eligible for credit.

Prices are subject to change without notice.

Terms of Payment: Subject to credit approval by Iowa Prison Industries. Standard terms are net 30 days from date of invoice.

Freight Policy

Consult our website at www.iaprisonind.com for the current freight policy.

Thank You for your patronage.

Instructions for Design Requests

When you request a design for a sign we need certain information to provide you with the sign you want. Please be sure to provide:

1. Both width and height of the sign.
2. Color of background and text.
3. If you have a preference, the size of text (height).
4. Any preference for font type and style.
5. Sheeting and sign substrate.
6. If you want holes in your sign please provide any preference for hole placement.
7. Note if you want square or radius corners.
8. If you require a specific color we need the Pantone color and number of each color.
9. Indicate either 1 or 2 sided sign.

If you want pictures or artwork on your sign that you are sending to us, please provide a file in one of the following types:

CorelDRAW - .CDR (Preferred format)
Adobe Illustrator - .AI (Preferred format)
Adobe Photoshop - .PSD (Preferred format)
Tag Image File Format - .TIF
JPEG File Interchange Format - .JPG
Graphics Interchange Format - .GIF
PC Paintbrush - .PCX
Portable Network Graphics - .PNG
Adobe Portable Document File - .PDF
Encapsulated Postscript - .EPS
Windows Bitmap - .BMP
Word Document - .DOC

We also request that you send any bitmap files at least at 200 dpi in their finished size (or as large as possible). If the resolution and file dpi sizes are sent to us at smaller or lesser sizes we have less to work with and your finished sign will be a lower quality than we can do with better starting materials.

Please double check the spelling and wording of any message you wish to have placed on your sign. Normally we place the exact text that is requested on a sign and we try to proofread anything sent to us. Unfortunately we could miss an incorrect name spelling or other less than obvious error so we appreciate it if you verify any text that you want on a sign.

Letter Visibility Chart

Maximum Readable Distance	Letter Height	Maximum Readable Distance	Letter Height
100 ft.	3"	750 ft.	18"
150 ft.	4"	1000 ft.	24"
200 ft.	6"	1250 ft.	30"
350 ft.	8"	1500 ft.	36"
400 ft.	9"	1750 ft.	42"
450 ft.	10"	2000 ft.	48"
525 ft.	12"	2250 ft.	54"
630 ft.	15"	2500 ft.	60"

Use the chart above to determine what letter size is required at a given distance for available visibility on any custom signs.



Recommended Minimum Letter Heights on Street Name Signs

Type of Mounting	Type of Street or Highway	Speed Limit	Recommended Minimum Letter Height	
			Initial Upper-Case	Lower-Case
Overhead	All types	All speed limits	12 inches	9 inches
Post-mounted	Multi-lane	More than 40 mph	8 inches	6 inches
Post-mounted	Multi-lane	40 mph or less	6 inches	4.5 inches
Post-mounted	2-lane	All speed limits	6 inches	4.5 inches*

* On local two-lane streets with speed limits of 25 mph or less, 4-inch initial upper-case letters with 3-inch lower-case letters may be used.

Font & Stroke Data

<i>Font Name</i>	<i>Example</i>
Arial	Sample Font
Arial Narrow	Sample Font
Arial Black	Sample Font
Helvetica	Sample Font
Helvetica Medium Cond.	Sample Font
HighwayGothic B	Sample Font
HighwayGothic C	Sample Font
HighwayGothic D	Sample Font
HighwayGothic E	Sample Font
HighwayGothic EM	Sample Font
Swiss721 Md Bt	Sample Font
Univers LT 67 Cond	Sample Font

These are examples of some of the some of the different font types used by IPI Sign-Sign Digital Divisions. Generally we use Highway Gothic font shown (in red above) for most general signage. Relative sizes can be seen by the examples above. Other font styles like the Swiss721 Md Bt are used on the Sheriff Vehicles. Speciality font styles and types can be use upon your request.

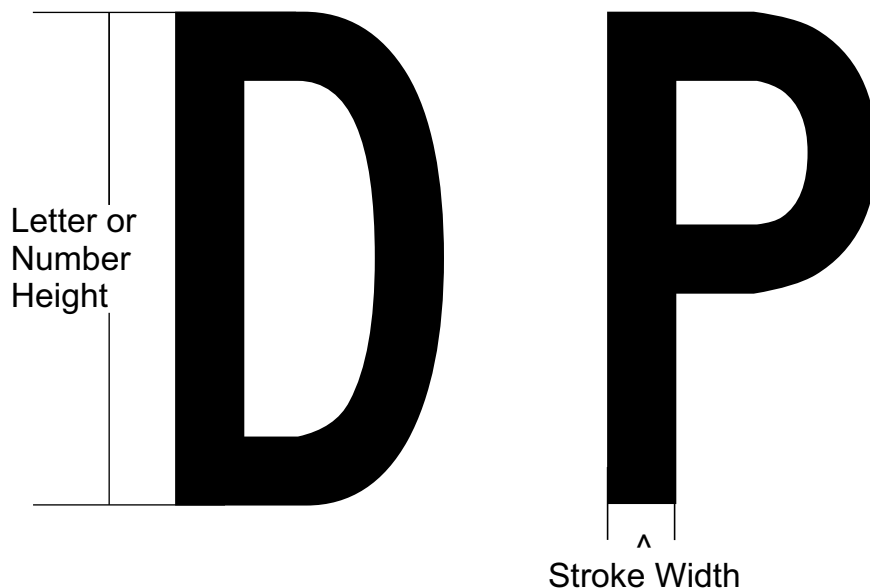

IPI Sign Division Font Examples

This will illustrate the Highway Gothic Fonts by Series, Height and Stroke Width.

Series B	
Letter Height	Stroke Width in Inches
3"	0.38
4"	0.50
5"	0.62
6"	0.75
8"	1.00
10"	1.25

Series C	
Letter Height	Stroke Width in Inches
3"	0.43
4"	0.56
5"	0.70
6"	0.84
8"	1.12
10"	1.41

Series D	
Letter Height	Stroke Width in Inches
3"	0.47
4"	0.62
5"	0.78
6"	0.94
8"	1.25
10"	1.56

Series E	
Letter Height	Stroke Width in Inches
3"	0.52
4"	0.69
5"	0.86
6"	1.03
8"	1.38
10"	1.75

Series EM	
Letter Height	Stroke Width in Inches
3"	0.60
4"	0.80
5"	1.00
6"	1.20
8"	1.60
10"	2.00

Printed Text Sizing

IPI screens and ink jet prints standard printed numbers & letters on specific sized pieces of material. We use highway gothic upper case & lower case fonts and the material is sized as shown below. Faces are sold by single print size, numbers 0 thru 9 & letter A thru Z. All other requests will be sold as a special.

Color requests are available using our standard inks and materials.

- a. High Intensity Prismatic and Diamond Grade Cubed sheeting use transparent inks.
- b. Controltac and Scotchcal sheeting use opaque inks.

Font Type - Highway Gothic HGB, HGC, HGD OR HGE

Font size	Face size
1"	1.5"x2"
2"	2.5"x3"
3"	3.5"x4"
4"	4"x5"
5"	5"x6"
6"	6"x7"
7"	7"x8"
8"	8"x9"
9"	9"x10"
10"	10"x11"
11"	11"x12"
12"	12"x13"

Example: 1" HGC Text



The face size would be as shown (1.5" x 2").
The letters "TURN HERE" would be cut for peeling and application.

Punch & Radius Standards

The following information shows the standards we use to determine if a sign should have a radius on each corner and also how and where to punch post holes.

1. All dimensions are in inches.
2. All bolt holes are punched at .4375" (7/16") , unless the size of the blank is 4" in height or width or below, then we use a .2500 (1/4") hole punch.
3. All signs above 4" in height or width are given a radius unless on plywood or per customer request.
4. All holes are punched on 1" center spacing unless otherwise requested (Note: If we alter these specifications for any reason we will so note the changes on the specification layout we send upon request).
5. The width of a sign is from left to right at its greatest point. The message and/or symbol will be read accordingly. When ordering please state the width, then the height.
6. The height of a sign is from top to bottom at its greatest point.

Triangular signs are measured from point to point on a side before a radius is added to the sign.

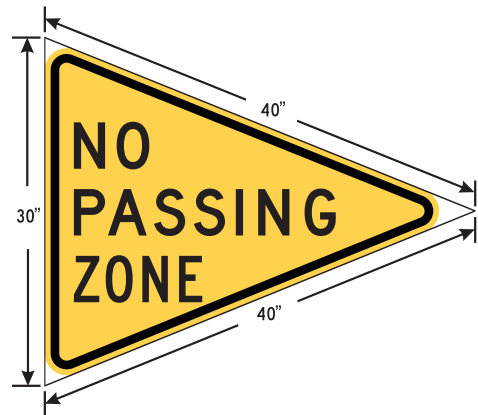

7. Post holes: Use whichever dimension is smallest (i.e. width or height) to determine how many posts are to be used.
 - a. Sizes up to to 41.99" use 1 post.
 - b. Sizes 42" and above use 2 posts.

Single Post sign Height of sign	<u>Vertical</u> hole spacing Inches between holes	Double post sign Width of sign	<u>Horizontal</u> hole spacing Inches between holes
Under 4"	No holes	42" to 48"	30" centers
4" to 6"	3" centers	72" and under	36" centers
7" to 10"	6" centers	96" and under	48" centers
11" to 14"	9" centers	120" and under	60" centers
15" to 17"	12" centers	*Vertical hole spacing on a 2 post sign is the same as a single post sign.	
18" to 22"	15" centers		
23" to 26"	18" centers		
27" to 30"	24" centers		
36" and under	24" centers		
48" and under	30" centers		
60" and under	36" centers		

If more posts holes are required for a sign than stated above, please request in your order along with a drawing of the hole punch location you are requesting. And if you want none, please state this on your order.

8. Radius: Our standard sizes are: 1/2", 3/4", 1", 1-1/2", 1-7/8", 2" and 3".

<u>Size</u>	<u>Radius</u>
Shortest side of sign	Shape of sign corner
Under 4" blank	Sq corner or Nip cut
4" blank	1/2" radius
Under 6" blank	1" radius
Under 30" blank	1-1/2" radius
Under 36" blank	1-7/8" radius
Under 48" blank	2" radius
48" blank and above	3" radius

Please indicate on your order if your desired radius is not one of the standards above.

The following are the IPI standard punch codes that will appear on your order / layouts when used:

VR = Vertical Rectangle / **HR** = Horizontal Rectangle / **D** = Diamond mount / **SQ** = Square Mount

R = Round / **O** = Octagon / **P** = Pentagon / **C** = County Route Marker / **I** = Interstate Shield

ST = Street Marker / **PM** = Property Marker

0 = No Post Holes / **1** = 1 Post / **2** = 2 Posts / **3** = 3 Posts

A = Radius corners / **B** = Square Corners



Posts & Post Assembly Data

Iowa Prison Industries Posts

Part Number	Description
FPOSTRND10GAL	Round Post 2-3/8" x 10'
FPOSTSQ10X1.75GA14	Square Post 10' x 1-3/4" 14 Gauge
FPOSTSQ10X2GA14	Square Post 10' x 2" 14 Gauge
FPOSTSQ12X1.75GA14	Square Post 12' x 1-3/4" 14 Gauge
FPOSTSQ12X2GA12	Square Post 12' x 2" 12 Gauge
FPOSTSQ12X2GA14	Square Post 12' x 2" 14 Gauge
FPOSTSQ14X2GA14	Square Post 14' x 2" 14 Gauge
FPOSTSQ3X2.25GA12	Square Post 3' x 2-1/4" 12 Gauge
FPOSTSQ4X2GA12	Square Post 4' x 2" 12 Gauge
FPOSTSQ4X2.25GA12	Square Post 4' x 2-1/4" 12 Gauge
FPOSTSQ8X1.75GA14	Square Post 8' x 1-3/4" 14 Gauge
FPOSTUC10FT2LB	U-Channel Post 10' x 2 Lbs.
FPOSTUC10FT2.5LB	U-Channel Post 10' x 2.5 Lbs.
FPOSTUC2FT1.12LB	U-Channel Post 2' x 1.12 Lbs.
FPOSTUC6FT1.12LB	U-Channel Post 6' 1.12 Lbs.
FPOSTUC8FT1.12LB	U-Channel Post 8' 1.12 Lbs.
FPOSTUC8FT2LB	U-Channel Post 8' 2 Lbs.

Square Posts: Listed by Length (feet) and Width (inches).

Posts consist of square perforated, welded steel tubing.

All posts are galvanized in conformance with ASTM A653, G90, Structural quality, Grade 40, Class I.

Holes are 7/16" punched on 1" centers, on all 4 sides, down the entire length of the post.

U-Channel Posts: Listed by Length (feet) and Width (inches).

Steel posts are green baked on alkyd resin, gloss enamel or hot galvanized after fabrication.

Holes are 3/8" punched on 1" centers, on center line of the entire length of the post.

Additional post sizes are available by a quote upon request. Allow a minimum of 8 weeks for delivery.

Hardware needed to mount signs to post

U-Channel Posts

	Times # of holes	Times # of bolts	Times # of holes
Size of Posts	Bolts Needed	Washers needed	Nuts needed
1.12 #	RHDWBOLTSSTL10230	RHDWWSRSTEEL55110	RHDWNUTSTL14960
2 #	RHDWBOLTSSTL10200	RHDWWSRSTEEL55110	RHDWNUTSTL14960
2.5 #	RHDWBOLTSSTL10200	RHDWWSRSTEEL55110	RHDWNUTSTL14960
3 #	RHDWBOLTSSTL10200	RHDWWSRSTEEL55110	RHDWNUTSTL14960

Square Posts

	Times # of holes	Times # of bolts	Times # of holes
Size of Posts	Bolts Needed	Washers needed	Nuts needed
1-3/4"	RHDWBOLTSSTL10200	RHDWWSRSTEEL55110	RHDWNUTSTL14960
2"	RHDWBOLTSSTL10210	RHDWWSRSTEEL55110	RHDWNUTSTL14960
2-1/4"	RHDWBOLTSSTL10210	RHDWWSRSTEEL55110	RHDWNUTSTL14960

3M recommends that nylon washers (RHDWWSRNYLON55100) are used on the sheeted side of signs.

IOWA PRISON INDUSTRIES SQUARE POST ASSEMBLIES & FASTENERS

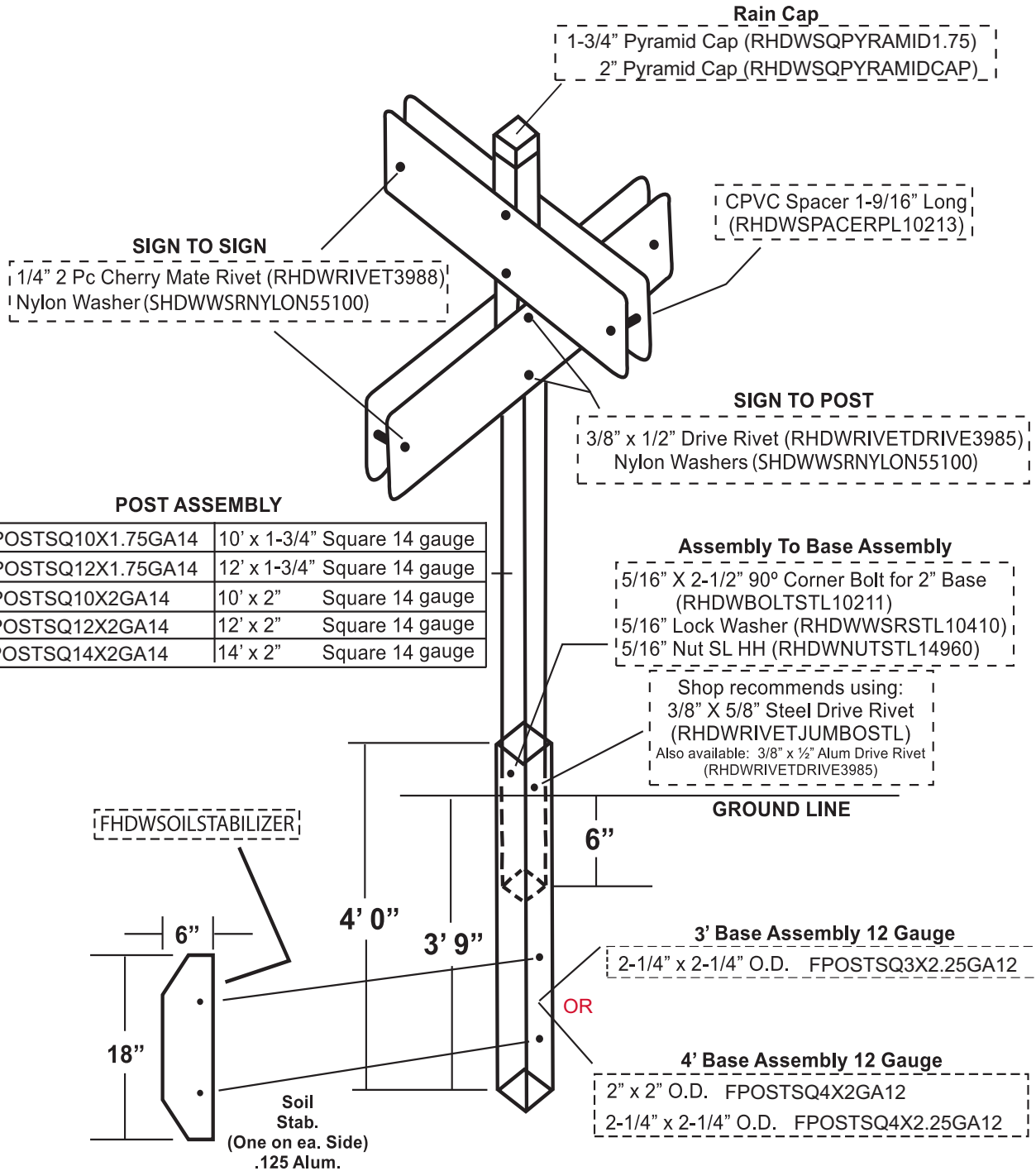

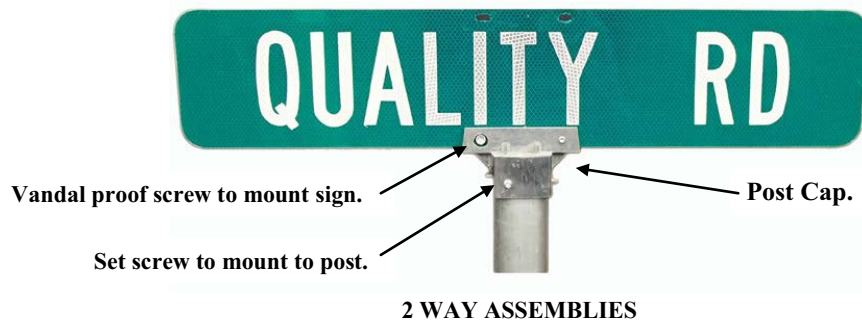

STREET MARKER HARDWARE



FHDW2WAYRND (2-3/8" Round post with 12" blade holder)

- 1 EA - [RHDWBRKTVSS10455](#) (Post cap)
- 4 EA - [RHDWBRKTSCR10390](#) (Set screw to mount to post)
- 2 EA - [RHDWBRKTSCR10400](#) (Vandal proof screw to mount sign)



FHDW2WAYRNDSTD (2-3/8" Round post with 5 1/4" blade holder)

- 1 EA - [RHDWBRKTRND10450](#) (Post cap)
- 4 EA - [RHDWBRKTSCR10390](#) (Set screw to mount to post)
- 2 EA - [RHDWBRKTSCR10400](#) (Vandal proof screw to mount sign)



FHDW2WAYSQ1.75 (1-3/4" Square post with 12" blade holder)

- 1 EA - [RHDWBRKTVS-12FCAP](#) (Post cap)
- 4 EA - [RHDWBRKTSCR10390](#) (Set screw to mount to post)
- 2 EA - [RHDWBRKTSCR10400](#) (Vandal proof screw to mount sign)



FHDW2WAYSQ1.75STD (1-3/4" Square post with 5-1/4" blade holder)

- 1 EA - [RHDWBRKTVS2210456](#) (Post cap)
- 4 EA - [RHDWBRKTSCR10390](#) (Set screw to mount to post)
- 2 EA - [RHDWBRKTSCR10400](#) (Vandal proof screw to mount sign)

STREET MARKER HARDWARE



FHDW2WAYSQ2 (2" Square post with 12" blade holder)
1 EA - [RHDWBRKTVS-12SQCAP](#) (Post cap)
4 EA - [RHDWBRKTSCR10390](#) (Set screw to mount to post)
2 EA - [RHDWBRKTSCR10400](#) (Vandal proof screw to mount sign)



FHDW2WAYSQ2STD (2" Square post with 5-1/4" blade holder)
1 EA - [RHDWBRKTVS2210457](#) (Post cap)
4 EA - [RHDWBRKTSCR10390](#) (Set screw to mount to post)
2 EA - [RHDWBRKTSCR10400](#) (Vandal proof screw to mount sign)



FHDW2WAYUC (U-Channel post with 12" blade holder 90°)
1 EA - [RHDWBRKTVS-12U-CCAP](#) (Post cap)
2 EA - [RHDWWSRSTL10410](#) (Lock washer for mounting to post)
2 EA - [RHDWBOLTSTL10320](#) (Bolt for mounting to post)
2 EA - [RHDWBRKTSCR10400](#) (Vandal proof screw to mount sign)



FHDW2WAYUCSTD (U-Channel post with 5-1/4" blade holder 90°)
1 EA - [RHDWBRKTUC10490](#) (Post cap)
2 EA - [RHDWSRSTL10410](#) (Lock washer for mounting to post)
2 EA - [RHDWBOLTSTL10320](#) (Bolt for mounting to post)
2 EA - [RHDWBRKTSCR10400](#) (Vandal proof screw to mount sign)



FHDW2WAYUC180 (U-Channel post with 12" blade holder 180°)
1 EA - [RHDWBRKTVS12UCAP180](#) (Post cap)
2 EA - [RHDWWSRSTL10410](#) (Lock washer for mounting to post)
2 EA - [RHDWBOLTSTL10320](#) (Bolt for mounting to post)
2 EA - [RHDWBRKTSCR10400](#) (Vandal proof screw to mount sign)



FHDW2WAYUCSTD180 (U-Channel post with 5-1/4" blade holder 180°)
1 EA - [RHDWBRKTUC180](#) (Post cap)
2 EA - [RHDWSRSTL10410](#) (Lock washer for mounting to post)
2 EA - [RHDWBOLTSTL10320](#) (Bolt for mounting to post)
2 EA - [RHDWBRKTSCR10400](#) (Vandal proof screw to mount sign)



4 WAY ASSEMBLIES

STREET MARKER HARDWARE



FHDW4WAYRND (2-3/8" Round post with 12" blade holder)

1 EA - [RHDWBRKTVSS10455](#) (Post cap)



1 EA - [RHDWBRKT90DVS-12](#) (90 degree cross piece)

4 EA - [RHDWBRKTSCR10390](#) (Set screw to mount to post)

6 EA - [RHDWBRKTSCR10400](#) (Vandal proof screw to mount sign)



FHDW4WAYRNDSTD (2-3/8" Round post with 5-1/4" blade holder)

1 EA - [RHDWBRKTRND10450](#) (Post cap)

1 EA - [RHDWBRKT90D10300](#) (90 degree cross piece)

4 EA - [RHDWBRKTSCR10390](#) (Set screw to mount to post)

6 EA - [RHDWBRKTSCR10400](#) (Vandal proof screw to mount sign)



FHDW4WAYSQ1.75 (1-3/4" Square post with 12" blade holder)

1 EA - [RHDWBRKTVS-12FCAP](#) (Post cap)

1 EA - [RHDWBRKT90DVS 12](#) (90 degree cross piece)

4 EA - [RHDWBRKTSCR10390](#) (Set screw to mount to post)

6 EA - [RHDWBRKTSCR10400](#) (Vandal proof screw to mount sign)



FHDW4WAYSQ1.75STD (1-3/4" Square post with 5-1/4" blade holder)

1 EA - [RHDWBRKTVS2210456](#) (Post cap)

1 EA - [RHDWBRKT90D10300](#) (90 degree cross piece)

4 EA - [RHDWBRKTSCR10390](#) (Set screw to mount to post)

6 EA - [RHDWBRKTSCR10400](#) (Vandal proof screw to mount sign)

STREET MARKER HARDWARE



- FHDW4WAYSQ2** (2" Square post with 12" blade holder)
 1 EA - [RHDWBRKTVS-12SQCAP](#) (Post cap)
 1 EA - [RHDWBRKT90DVS-12](#) (90 degree cross piece)
 4 EA - [RHDWBRKTSCR10390](#) (Set screw to mount to post)
 6 EA - [RHDWBRKTSCR10400](#) (Vandal proof screw to mount sign)



- FHDW4WAYSQ2STD** (2" Square post with 5-1/4" blade holder)
 1 EA - [RHDWBRKTVS2210457](#) (Post cap)
 1 EA - [RHDWBRKT90D10300](#) (90 degree cross piece)
 4 EA - [RHDWBRKTSCR10390](#) (Set screw to mount to post)
 6 EA - [RHDWBRKTSCR10400](#) (Vandal proof screw to mount sign)



- FHDW4WAYUC** (U-Channel post with 12" blade holder 90°)
 1 EA - [RHDWBRKTVS-12U-CCAP](#) (Post cap)
 1 EA - [RHDWBRKT90DVS-12](#) (90 degree cross piece)
 2 EA - [RHDWWSRSTL10410](#) (Lock washer for mounting to post)
 2 EA - [RHDWBOLTSTL10320](#) (Bolt for mounting to post)
 6 EA - [RHDWBRKTSCR10400](#) (Vandal proof screw to mount sign)



- FHDW4WAYUCSTD** (U-Channel post with 5-1/4" blade holder 90°)
 1 EA - [RHDWBRKTUC10490](#) (Post cap)
 1 EA - [RHDWBRKT90D10300](#) (90 degree cross piece)
 2 EA - [RHDWWSRSTL10410](#) (Lock washer for mounting to post)
 2 EA - [RHDWBOLTSTL10320](#) (Bolt for mounting to post)
 6 EA - [RHDWBRKTSCR10400](#) (Vandal proof screw to mount sign)



- FHDW4WAYUC180** (U-Channel post with 12" blade holder 180°)
 1 EA - [RHDWBRKTVS12UCAP180](#) (Post cap)
 1 EA - [RHDWBRKT90DVS-12](#) (90 degree cross piece)
 2 EA - [RHDWWSRSTL10410](#) (Lock washer for mounting to post)
 2 EA - [RHDWBOLTSTL10320](#) (Bolt for mounting to post)
 6 EA - [RHDWBRKTSCR10400](#) (Vandal proof screw to mount sign)



- FHDW4WAYUCSTD180** (U-Channel post with 5-1/4" blade holder 180°)
 1 EA - [RHDWBRKTUC180](#) (Post cap)
 1 EA - [RHDWBRKT90D10300](#) (90 degree cross piece)
 2 EA - [RHDWWSRSTL10410](#) (Lock washer for mounting to post)
 2 EA - [RHDWBOLTSTL10320](#) (Bolt for mounting to post)
 6 EA - [RHDWBRKTSCR10400](#) (Vandal proof screw to mount sign)

STREET MARKER HARDWARE

For Street Markers signs that are mounted on a **WOODEN** post

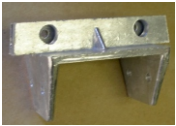

(Wooden post with 5 -1/4" blade holder 90°)

- 1 EA - [RHDWBRKTST10470](#) (Post cap)
- 2 EA - [RHDWBRKTSCR10400](#) (Vandal proof screw to mount sign)

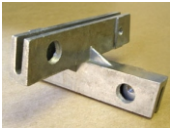

- 1 EA - [RHDWBRKT90D10300](#) (90 degree cross piece)
- 4 EA - [RHDWBRKTSCR10400](#) (Vandal proof screw to mount sign)



- 1 EA - [RHDWBRKT90DVS-12](#) (90 degree cross piece)
- 4 EA - [RHDWBRKTSCR10400](#) (Vandal proof screw to mount sign)



(Wooden post with 12" blade holder 90°)

- 1 EA - [SP-HARDWARE](#) (Post cap)
- 2 EA - [RHDWBRKTSCR10400](#) (Vandal proof screw to mount sign)

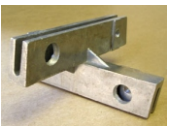

- 1 EA - [RHDWBRKT90D10300](#) (90 degree cross piece)
- 4 EA - [RHDWBRKTSCR10400](#) (Vandal proof screw to mount sign)



- 1 EA - [RHDWBRKT90DVS-12](#) (90 degree cross piece)
- 4 EA - [RHDWBRKTSCR10400](#) (Vandal proof screw to mount sign)

STREET MARKER HARDWARE

For Street Markers signs that are mounted on a **Extruded** substrate



(2-3/8" Round post with 5-1/4" blade holder)

1 EA - [RHDWBRACKETVS-1RND](#) (Post cap)

5 EA - [RHDWBRKTSCR10390](#) (Set screw to mount to post)



(To make 4-Way on top of above Post cap)

1 EA - [RHDWBRACKETVS-1CROSS](#) (90 degree 5-1/4" cross piece)

4 EA - [RHDWBRKTSCR10390](#) (Set screw to mount to post)



(To make 4-Way on top of above Post cap)

1 EA - [RHDWBRACKETEXTCROSS](#) (90 degree 12" cross piece)

4 EA - [RHDWBRKTSCR10390](#) (Set screw to mount to post)



(2-3/8" Round post with 12" blade holder)

1 EA - [RHDWBRACKETVS-12RND](#) (Post cap)

5 EA - [RHDWBRKTSCR10390](#) (Set screw to mount to post)



(To make 4-Way on top of above Post cap)

1 EA - [RHDWBRACKETVS-1CROSS](#) (90 degree 5-1/4" cross piece)

4 EA - [RHDWBRKTSCR10390](#) (Set screw to mount to post)



(To make 4-Way on top of above Post cap)

1 EA - [RHDWBRACKETEXTCROSS](#) (90 degree 12" cross piece)

4 EA - [RHDWBRKTSCR10390](#) (Set screw to mount to post)

STREET MARKER HARDWARE

For Street Markers signs that are mounted on a **Extruded** substrate



(1-3/4" Square post with 5-1/4" blade holder)

1 EA - [RHDWBRACKETVS-1SQ](#) (Post cap)

5 EA - [RHDWBRKTSCR10390](#) (Set screw to mount to post)



(To make 4-Way on top of above Post cap)

1 EA - [RHDWBRACKETVS-1CROSS](#) (90 degree 5-1/4" cross piece)

4 EA - [RHDWBRKTSCR10390](#) (Set screw to mount to post)

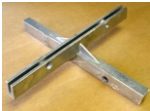

(To make 4-Way on top of above Post cap)

1 EA - [RHDWBRACKETEXTCROSS](#) (90 degree 12" cross piece)

4 EA - [RHDWBRKTSCR10390](#) (Set screw to mount to post)



(1-3/4" Square post with 12" blade holder)

1 EA - [SP-HARDWARE](#) (Post cap)

5 EA - [RHDWBRKTSCR10390](#) (Set screw mount to post)

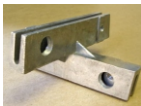

(To make 4-Way on top of above Post cap)

1 EA - [RHDWBRACKETVS-1CROSS](#) (90 degree 5-1/4" cross piece)

4 EA - [RHDWBRKTSCR10390](#) (Set screw to mount to post)



(To make 4-Way on top of above Post cap)

1 EA - [RHDWBRACKETEXTCROSS](#) (90 degree 12" cross piece)

4 EA - [RHDW BRKTSCR10390](#) (Set screw to mount to post)

STREET MARKER HARDWARE

For Street Markers signs that are mounted on a **Extruded** substrate



(2" Square post with 5-1/4" blade holder)

1 EA - [RHDWBRACKETVS-1SQ2](#) (Post cap)

5 EA - [RHDWBRKTSCR10390](#) (Set screw to mount to post)



(To make 4-Way on top of above Post cap)

1 EA - [RHDWBRACKETVS-1CROSS](#) (90 degree 5-1/4" cross piece)

4 EA - [RHDWBRKTSCR10390](#) (Set screw to mount to post)



(To make 4-Way on top of above Post cap)

1 EA - [RHDWBRACKETEXTCROSS](#) (90 degree 12" cross piece)

4 EA - [RHDWBRKTSCR10390](#) (Set screw to mount to post)



(2" Square post with 12" blade holder)

1 EA - [SP-HARDWARE](#) (Post cap)

5 EA - [RHDWBRKTSCR10390](#) (Set screw to mount to post)



(To make 4-Way on top of above Post cap)

1 EA - [RHDWBRACKETVS-1CROSS](#) (90 degree 5-1/4" cross piece)

4 EA - [RHDWBRKTSCR10390](#) (Set screw to mount to post)

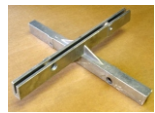

(To make 4-Way on top of above Post cap)

1 EA - [RHDWBRACKETEXTCROSS](#) (90 degree 12" cross piece)

4 EA - [RHDWBRKTSCR10390](#) (Set screw to mount to post)

STREET MARKER HARDWARE

For Street Markers signs that are mounted on a **Extruded** substrate



(U-Channel post with 5-1/4" blade holder 90°)

- 1 EA - [RHDWBRACKETVS-1UC](#) (Post cap)
- 2 EA - [RHDWBOLTSTL10320](#) (Bolt for mounting to post)
- 2 EA - [RHDWSRSTL10410](#) (Lock washer for mounting to post)
- 2 EA - [RHDWBRKTSCR10390](#) (Set screw to mount to post)



(To make 4-Way on top of above Post cap)

- 1 EA - [RHDWBRACKETVS-1CROSS](#) (90 degree 5-1/4" cross piece)
- 4 EA - [RHDWBRKTSCR10390](#) (Set screw to mount to post)



(To make 4-Way on top of above Post cap)

- 1 EA - [RHDWBRACKETEXTCROSS](#) (90 degree 12" cross piece)
- 4 EA - [RHDWBRKTSCR10390](#) (Set screw to mount to post)



(U- Channel post with 5-1/4" blade holder 180°)

- 1 EA - [SP-HARDWARE](#) (Post cap)
- 2 EA - [RHDWBOLTSTL10320](#) (Bolt for mounting post)
- 2 EA - [RHDWSRSTL10410](#) (Lock washer for mounting to post)
- 2 EA - [RHDWBRKTSCR10390](#) (Set screw to mount to post)



(To make 4-Way on top of above Post cap)

- 1 EA - [RHDWBRACKETVS-1CROSS](#) (90 degree 5-1/4" cross piece)
- 4 EA - [RHDWBRKTSCR10390](#) (Set screw to mount to post)



(To make 4-Way on top of above Post cap)

- 1 EA - [RHDWBRACKETEXTCROSS](#) (90 degree 12" cross piece)
- 4 EA - [RHDWBRKTSCR10390](#) (Set screw to mount to post)

HARDWARE

Part number	Part Description	Specify choice
RHDWBRKT45D10350	ADJUSTABLE 45 DEGREE BRACKET	Flat blade or Extruded blade
RHDWSQPYRAMID1.75	for 1-3/4" Square Post Rain Cap	
RHDWSQPYRAMIDCAP	for 2" Square Post Rain Cap	
FHDWBIGBOYDC	U-CHANNEL POST DRIVER	
FCONCRETEBASE-2.00	for 1-3/4" Square Post	
FCONCRETEBASE-2.25	for 2" Square Post	
RHDWCANTILR10510	STREET MARKER BRACKET	
RHDWCANTILEVERMETRO	STREET MARKER BRACKET	
RHDWRIVETDRIVE3985	3/8" X 1/2" ALUMINUM Rivet	
RHDWRIVET3988	1/4" X 1-1/2" ALUMINUM Cherry Mate Rivet	
RHDWRIVETJUMBOALUM	3/8" X 5/8" ALUMINUM Rivet	
RHDWRIVETJUMBOSTL	3/8" X 5/8" STEEL Rivet	
RHDWBRKTSCR10390	5/16" ALLEN SET SCREW	
RHDWBRKTSCR10400	5/16" X 1/2" STEEL CAP SCREW	
RHDWSTRAPASEM38000	SET INCLUDES 2 BRACKETS Pole strap	
RHDWSIGNLINK	2-3/4" X 1-7/8" Fence Link	
RHDWBOLTALUM10025	3/8" X 1" ALUMINUM	
RHDWBOLTSTL10055	3/8" X 2-1/4" STEEL	
RHDWBOLTALUM10090	5/16" X 3/4" ALUMINUM	
RHDWBOLTSTL10200	5/16" X 2-1/4" STEEL	
RHDWBOLTSTL10210	5/16" X 2-3/4" STEEL	
RHDWBOLTSTL10211	5/16" X 2-1/2" STEEL 90 DEG CORNER BOLT	
RHDWBOLTSTL10230	5/16" X 1-1/2" STEEL	
RHDWBOLTSTL10320	5/16" X 3/4" STEEL	
RHDWWSRSTL10410	5/16" LOCK WASHER STEEL	
RHDWWSRSTL55030	3/8" LOCK WASHER ALUM	
RHDWWSRSTL55040	5/16" LOCK WASHER ALUM	
RHDWWSRALUM55050	7/16" X 1" FLAT ALUM	
RHDWWSRNYLON55100	3/8" X 7/8" NYLON	
RHDWWSRSTEEL55110	11/16" X 11/32" X 1/16" STEEL ZINC PLATED	
RHDWNUTALUM3300	3/8" ALUMINUM HEX	
RHDWNUTALUM14900	3/8" ALUMINUM HEX	
RHDWNUTALUM14910	5/16" ALUM SELF LOCKING HEX	
RHDWNUTSTL14940	3/8" STEEL GALVANIZED HEX	
RHDWNUTSTL14960	5/16" STEEL SELF LOCKING HEX	
RHDWNUTSTL14970	5/16" STEEL HEX	
RHDWDEL3.25RNDAMBER	Amber Delineator	
RHDWDEL3.25RNDRED	Red Delineator	
RHDWDEL3.25RND SILVER	Silver Delineator	
RHDWDELINGBLANK	Delineator Guardrail Blank	
FFLAGMOUNTSINGLE	Flag Mount Bracket Single	
FFLAGMOUNTDOUBLE	Flag Mount Bracket Double	
FSIGNSTANDAFRAME	Stock A-Frame 25" X 36" WHITE	
FSTEPSTAKE6X30	Step Stake 6" X 30" for corrugated signs	
SPBANNERRETRACTOR	for Floor Banners Display	
SPBANNERRETRACTORTT	for Table Top Banners Display	
FROLLDSTANDS48A	SPRING LOADED w/ ALUMINUM LEGS	
FROLLDSTANDS48C	SPRING LOADED w/ ALUMINUM LEGS	
FROLLUPSTANDUC	SPRING LOADED w/ STEEL LEGS	
FROLLUPSTANDUCA	SPRING LOADED w/ ALUMINUM LEGS	
FROLLUPSTANDUCR	RIDIG STAND w/ STEEL LEGS	

HARDWARE



TO



RHDWBRKT45D10350
ADJUSTABLE 45 DEGREE BRACKET
 Specify for Flat blade or Extruded



RHDWSQPYRAMID1.75
 for 1-3/4" Square Post
Rain Cap

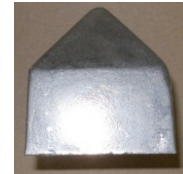

RHDWSQPYRAMIDCAP
 for 2" Square Post
Rain Cap

U-CHANNEL POST DRIVER



FHDWBIGBOYDC

CONCRETE POST BASES

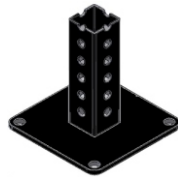

FCONCRETEBASE-2.00
 for 1-3/4" Square Post
 OR
 FCONCRETEBASE-2.25
 for 2" Square Post

STREET MARKER BRACKET



RHDWCANTILR10510



RHDWCANTILEVERMETRO

RIVETS

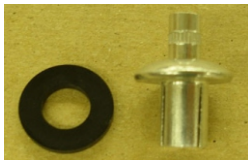

RHDWRIVETDRIVE3985
 3/8" X 1/2" ALUMINUM

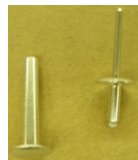

RHDWRIVET3988
 1/4" X 1-1/2" ALUMINUM
 CHERRY MATE RIVET

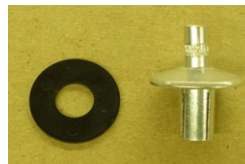

RHDWRIVETJUMBOALUM
 3/8" X 5/8" ALUMINUM



RHDWRIVETJUMBOSTL
 3/8" X 5/8" STEEL

SET SCREW

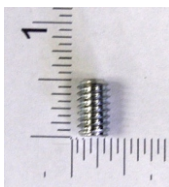

RHDWBRKTSCR10390
 5/16" ALLEN SET SCREW

CAP SCREW



RHDWBRKTSCR10400
 5/16" X 1/2" STEEL CAP SCREW

POLE STRAP



RHDWSTRAPASEM38000
 SET INCLUDES 2 BRACKETS

FENCE LINK

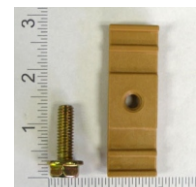

RHDWSIGNLINK
 2-3/4" X 1-7/8"

HARDWARE

BOLTS



RHDWBOLTALUM10025
3/8" X 1" ALUMINUM



RHDWBOLTSTL10055
3/8" X 2-1/4" STEEL

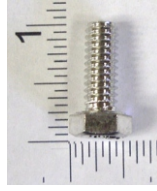

RHDWBOLTALUM10090
5/16" X 3/4" ALUMINUM



RHDWBOLTSTL10200
5/16" X 2-1/4" STEEL



RHDWBOLTSTL10210
5/16" X 2-3/4" STEEL



RHDWBOLTSTL10211
5/16" X 2-1/2" STEEL
90 DEG CORNER BOLT



RHDWBOLTSTL10230
5/16" X 1-1/2" STEEL



RHDWBOLTSTL10320
5/16" X 3/4" STEEL

WASHERS

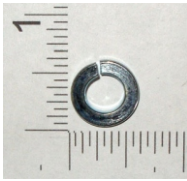

RHDWWSRSTL10410
5/16" LOCK WASHER STEEL



RHDWWSRSTL55030
3/8" LOCK WASHER ALUM

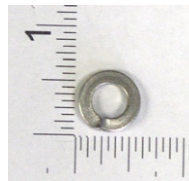

RHDWWSRSTL55040
5/16" LOCK WASHER ALUM

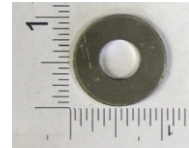

RHDWWSRALUM55050
7/16" X 1" FLAT ALUM

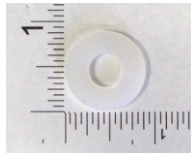

RHDWWSRNYLON55100
3/8" X 7/8" NYLON

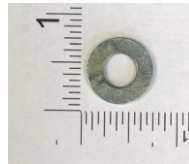

RHDWWSRSTEEL55110
11/16" X 11/32" X 1/16"
STEEL ZINC PLATED

NUTS

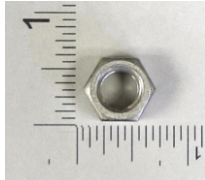

RHDWNUTALUM3300
3/8" ALUMINUM HEX

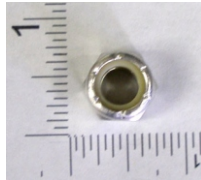

RHDWNUTALUM14900
3/8" ALUMINUM HEX

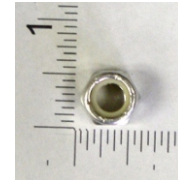

RHDWNUTALUM14910
5/16" ALUM SELF LOCKING HEX

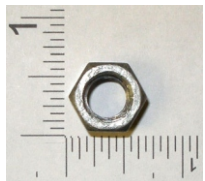

RHDWNUTSTL14940
3/8" STEEL GALVANIZED HEX

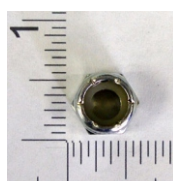

RHDWNUTSTL14960
5/16" STEEL SELF LOCKING HEX

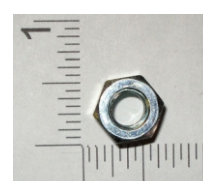

RHDWNUTSTL14970
5/16" STEEL HEX

HARDWARE

DELINEATORS

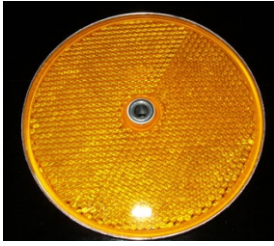

RHDWDEL3.25RNDAMBER



RHDWDEL3.25RNDRED

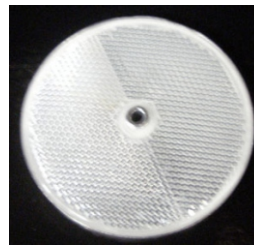

RHDWDEL3.25RND SILVER

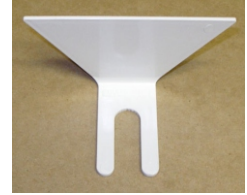

RHDWDELINGBLANK



FFLAGMOUNTSINGLE

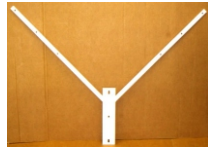

FFLAGMOUNTDOUBLE



FSIGNSTANDAFRAME

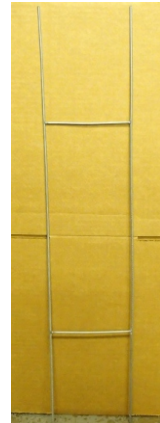

FSTEPSTAKE6X30



SPBANNERRETRACTOR
for Floor Banners Display

OR

SPBANNERRETRACTORTT
for Table Top Banners Display



FROLLDSTAND548A -
SPRING LOADED w/ ALUMINUM LEGS

FROLLDSTAND548C -
SPRING LOADED w/ ALUMINUM LEGS

FROLLUPSTANDUC -
SPRING LOADED w/ STEEL LEGS

FROLLUPSTANDUCA -
SPRING LOADED w/ ALUMINUM LEGS

FROLLUPSTANDUCR -
RIDIG STAND w/ STEEL LEGS

CONTACT SALES OFFICE FOR INFORMATION ON ADDITIONAL HARDWARE AVAILABLE.

Refurbish Information

Refurbished signs can be a substantial savings to you as compared to purchasing new signs. All refurbished signs are used blanks that have been cleaned and recut to a standard size with new sign face material applied.

- 24" and 30" stop signs.
- 12" x 18" parking or wording of your choice.
- 18" x 24" chevrons or weight limits, etc.
- Cannot refurbish anything under 12" x 12".

Refurbished signs are covered with Hi-intensity Prismatic, or Diamond Grade Cubed sheeting to meet DOT specifications.

You may request one of two options when sending in signs for refurbishing.

1. Clean and re-face.
2. Clean.

All signs subject to IPI inspection & rejection.

Refurbished signs are guaranteed to be like new when our refurbish process is complete.

For pick up and delivery or additional information call: 1-800-336-5863.

It is advisable to replace all traffic control and street identification signs which have exceeded their effective performance life. Emergency vehicles and motorists driving your city streets can readily identify residences and businesses with reflective street marker signs. Iowa Prison Industries will work with your city to provide signs that communicate more effectively thus providing greater safety and fewer accidents on your streets.

